

Alarm Switch

Alarm Switch

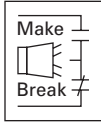

For remote indication of automatic trip operation. Does not function with manual switching; however, it will operate when either a shunt trip or under-voltage release is operated. A “make” contact closes and a “break” contact opens when the alarm/lockout switch operates. The switch automatically resets when the circuit breaker is reset.

Table 45-181. F-Frame Electrical Rating Data ①②

Maximum Voltage	Frequency	Maximum Current Amperes	Dielectric Withstand Voltage
600	50/60 Hz	6	2500
125	dc	0.50 ③	
250	dc	0.25 ③	

Multi-Pole Circuit Breakers

600	50/60 Hz	6	2500
125	dc	0.50 ③	
250	dc	0.25 ③	

Single-Pole Circuit Breakers

125/250	50/60 Hz	6 ③	2000
28	dc	3 ③	
28	dc	5 ④	

- ① Endurance: 6000 electrical operations plus 4000 mechanical operations.
- ② Endurance: 6000 electrical operations plus 2000 mechanical operations.
- ③ Non-inductive load.
- ④ Inductive (L/R = 0.026).

Table 45-182. J-Frame Electrical Rating Data ⑤⑥

Maximum Voltage	Frequency	Maximum Current Amperes	Dielectric Withstand Voltage
600	50/60 Hz	6	2500
125	dc	0.50 ⑦	
250	dc	0.25 ⑦	

- ⑤ Endurance: 6000 electrical operations plus 2000 mechanical operations.
- ⑥ Pigtail wire size: 18 AWG (0.82 mm²).
- ⑦ Non-inductive load.

Table 45-183. K-Frame Electrical Rating Data ⑧⑨

Maximum Voltage	Frequency	Maximum Current Amperes	Dielectric Withstand Voltage
600	50/60 Hz	6	2500
125	dc	0.50 ⑩	
250	dc	0.25 ⑩	

- ⑧ Pigtail wire size: 18 AWG (0.82 mm²).
- ⑨ Endurance: 5,000 electrical operations plus 1000 mechanical operations.
- ⑩ Non-inductive load.

Table 45-184. L-Frame Electrical Rating Data ⑪⑫

Maximum Voltage	Frequency	Maximum Current Amperes	Dielectric Withstand Voltage
600	50/60 Hz	6	2500
125	dc	0.50 ⑬	
250	dc	0.25 ⑬	

- ⑪ Pigtail wire size: 18 AWG (0.82 mm²).
- ⑫ Endurance: 5,000 electrical operations plus 1000 mechanical operations.
- ⑬ Non-inductive load.

Alarm Switch

Table 45-185. G-Frame Alarm Switch (RH Only) ①

Electrical Ratings			Contact Arrangement	Factory Suffix	Adder U.S. \$	Catalog Number ②③④	Price U.S. \$
Volts	Frequency	Amperes					

Alarm Switch

240	50/60 Hz	6	1 Make/1 Break	B3		1288C75G03	
-----	----------	---	----------------	----	--	------------	--

Alarm Switch Auxiliary Switches Combination

240	50/60 Hz	6	1 Make/1 Break and 1a/1b	B13		1288C76G09	
-----	----------	---	--------------------------	-----	--	------------	--

- ① F-Frame circuit breakers are factory sealed. Underwriters Laboratories, requires that internal accessories be installed at the factory. Internal accessories are UL listed for factory installation under E7819. Where local codes and standards permit and UL listing is not required, internal accessories can be field installed. Accessory installation should be done before the circuit breaker is mounted and connected.
- ② Includes 24-inch (609.6 mm) external pigtail leads, 18 AWG (16-.010).
- ③ A maximum of two internal accessories may be mounted in a 3-pole circuit breaker.
- ④ Suitable for mounting in right pole only of 2- or 3-pole breaker.

Table 45-186. F-Frame and HMCP (F) Alarm Switch ⑤

Number of Contacts (Make and Break)	Mounting Location (Pole)	Factory Mounted								Field Mounted					
		Connection Type and Location										Field Installation Kits ⑥⑦			
		18-Inch (457.2 mm) Pigtail Leads								Terminal Block					
		Same Side		Rear ⑧		Opposite Side		Same Side		Pigtail Leads		Terminal Block			
Suffix Number	Adder U.S. \$	Suffix Number	Adder U.S. \$	Suffix Number	Adder U.S. \$	Suffix Number	Adder U.S. \$	Suffix Number	Adder U.S. \$	Catalog Number	Price U.S. \$	Catalog Number	Price U.S. \$		

1	Left ⑨ Right	B01 B05		B02 B06		B03 B07		B04 B08		A1L1LPK A1L1RPK		A1L1LTK A1L1RTK	
2	Left ⑨ Right	B09 B12		B10 B13		— —		B11 B14		A2L1LPK A2L1RPK		A2L1LTK A2L1RTK	
1 (Make Only)	Single-Pole	B15 ⑩		—		—		—		—		—	

- ⑤ F-Frame circuit breakers are factory sealed. Underwriters Laboratories, requires that internal accessories be installed at the factory. Internal accessories are UL listed for factory installation under E7819. Where local codes and standards permit and UL listing is not required, internal accessories can be field installed. Accessory installation should be done before the circuit breaker is mounted and connected.
- ⑥ Not listed with Underwriters Laboratories, for field installation.
- ⑦ For F-Frame HMCP, add "M" to the beginning of catalog number.
- ⑧ Standard pigtail lead exit location.
- ⑨ Standard mounting location.
- ⑩ Factory installation only. Leads exit load end of circuit breaker.

Table 45-187. J-Frame and HMCP (J) Alarm Switch

Number of Contacts (Make and Break)	Mounting Location (Pole)	Factory Mounted								Field Mounted					
		Connection Type and Location										Field Installation Kits ⑪			
		18-Inch (457.2 mm) Pigtail Leads								Terminal Block					
		Same Side		Rear ⑫		Opposite Side		Same Side		Pigtail Leads		Terminal Block			
Suffix Number	Adder U.S. \$	Suffix Number	Adder U.S. \$	Suffix Number	Adder U.S. \$	Suffix Number	Adder U.S. \$	Suffix Number	Adder U.S. \$	Catalog Number	Price U.S. \$	Catalog Number	Price U.S. \$		

1	Left ⑬ Right	B01 B05		B02 B06		B03 B07		B04 B08		A1L2LPK A1L2RPK		A1L2LTK A1L2RTK ⑭	
---	-----------------	------------	--	------------	--	------------	--	------------	--	--------------------	--	----------------------	--

- ⑪ Listed with Underwriters Laboratories, for field installation on interchangeable trip unit breakers under E64983.
- ⑫ Standard mounting location.
- ⑬ Standard mounting location — leads exit rear of breaker.
- ⑭ Standard pigtail lead exit location.

Alarm Switch

Table 45-188. K-Frame and HMCP (K) Alarm Switch

Number of Sets of Contacts (1M and 1B)	Mounting Location (Pole)	Factory Mounted								Field Mounted			
		Connection Type and Location								Field Installation Kits ①			
		18-Inch (457.2 mm) Pigtail Leads								Terminal Block			
		Same Side				Rear ②		Opposite Side		Same Side		Pigtail Leads	
Suffix Number	Adder U.S. \$	Suffix Number	Adder U.S. \$	Suffix Number	Adder U.S. \$	Suffix Number	Adder U.S. \$	Suffix Number	Adder U.S. \$	Catalog Number	Price U.S. \$	Catalog Number	Price U.S. \$
1	Left ③	B01		B02		B03		B04		A1L3LPK		A1L3LTK	
	Right ④	B05		B06		B07		B08		A1L3RPK		A1L3RTK	
2	Left ③	B09		B10		—		B11		A2L3LPK		A2L3LTK	
	Right ④	B12		B13		—		B14		A2L3RPK		A2L3RTK	

① Listed with Underwriters Laboratories, for field installation on interchangeable trip unit breakers under E64983.

② Standard mounting location.

③ Standard mounting location — leads exit rear of breaker.

④ Breakers with K-Frame OPTIM 550 can only accept accessories in left pole.

Table 45-189. L-Frame and HMCP (L) Alarm Switch

Number of Sets of Contacts (1M and 1B)	Mounting Location (Pole)	Factory Mounted								Field Mounted			
		Connection Type and Location								Field Installation Kits ⑤			
		18-Inch (457.2 mm) Pigtail Leads								Terminal Block			
		Same Side				Rear ⑥		Opposite Side		Same Side		Pigtail Leads	
Suffix Number	Adder U.S. \$	Suffix Number	Adder U.S. \$	Suffix Number	Adder U.S. \$	Suffix Number	Adder U.S. \$	Suffix Number	Adder U.S. \$	Catalog Number	Price U.S. \$	Catalog Number	Price U.S. \$
1	Left ⑦	B01		B02		B03		B04		A1L4LPK		A1L4LTK	
	Right	B05		B06		B07		B08		A1L4RPK		A1L4RTK	
2	Left ⑦	B09		B10		—		B11		A2L4LPK		A2L4LTK	
	Right	B12		B13		—		B14		A2L4RPK		A2L4RTK	

⑤ Listed with Underwriters Laboratories, for field installation on interchangeable trip unit breakers under E64983.

⑥ Standard mounting location.

⑦ Standard mounting location — leads exit rear of breaker.

Auxiliary Switch

Auxiliary Switch

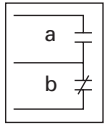

The Auxiliary Switch provides circuit breaker contact status information by monitoring the position of the molded cross bar which contains the moving contact arms. The auxiliary switch is used for remote indication and interlock system verification, and consists of one or two SPDT switches housed in a plug-in module. Each SPDT switch has one "a" and one "b" contact. When the circuit breaker contacts are open, the "a" contact is open and the "b" contact is closed.

Table 45-190. F-Frame Electrical Rating Data ①②

Maximum Voltage	Frequency	Maximum Current Amperes	Dielectric Withstand Voltage
125 ③	50/60 Hz	1	2500
600	50/60 Hz	6	
125	dc	0.50 ④	
250	dc	0.25 ④	

- ① Endurance: 6000 electrical operations plus 4000 mechanical operations.
- ② Pigtail wire size: 18 AWG (0.82 mm²).
- ③ For use in electronic circuit of 100 micro amperes and 15 Vdc minimum.
- ④ Non-inductive load.

Table 45-191. J-Frame Electrical Rating Data ⑤⑥

Maximum Voltage	Frequency	Maximum Current Amperes	Dielectric Withstand Voltage
600	50/60 Hz	6	2500
125	dc	0.50 ⑦	
250	dc	0.25 ⑦	

- ⑤ Endurance: 6000 electrical operations plus 4000 mechanical operations.
- ⑥ Pigtail wire size: 18 AWG (0.82 mm²).
- ⑦ Non-inductive load.

Table 45-194. G-Frame Auxiliary Switch (RH only)

Electrical Ratings			Contact Arrangement	Factory Suffix	Adder U.S. \$	Catalog Number ⑧⑨	Price U.S. \$
Volts	Frequency	Amperes					
240	50/60 Hz	6	1a/1b	A3		1288C74G03	
240	50/60 Hz	6	2a/2b	A6		1288C73G03	

- ⑧ Includes 24-inch external pigtail leads, 18 AWG (16-.010).
- ⑨ A maximum of two internal accessories may be mounted in a 3-pole circuit breaker. Suitable for mounting in right pole only of 2- or 3-pole breaker.

Table 45-195. F-Frame and HMCP (F) Auxiliary Switch

Number of Contacts a and b	Mounting Location (Pole)	Factory Mounted								Field Mounted											
		Connection Type and Location								Field Installation Kits ⑩											
		18-Inch (457.2 mm) Pigtail Leads								Pigtail Leads		Terminal Block									
		Same Side				Rear ⑪		Opposite Side		Same Side		Catalog Number	Price U.S. \$	Catalog Number	Price U.S. \$						
Suffix Number	Adder U.S. \$	Suffix Number	Adder U.S. \$	Suffix Number	Adder U.S. \$	Suffix Number	Adder U.S. \$	Suffix Number	Adder U.S. \$												
1	Left ⑫	A01		A02		A03		A04		A1X1PK		A1X1LTK									
		A15 ⑬		A16 ⑬		A17 ⑬		—						E1X1PK		—					
		A05		A06		A07		A08										A1X1PK		A1X1RTK ⑭	
		A18 ⑬		A19 ⑬		A20 ⑬		—													
2	Left ⑫	A09		A10		—		A11		A2X1LPK		A2X1LTK									
		A21 ⑬		A22 ⑬		—		—						E2X1LPK		—					
		A12		A13		—		A14										A2X1RPK		A2X1RTK ⑭	
		A23 ⑬		A24 ⑬		—		—													

- ⑩ Standard pigtail lead exit location.
- ⑪ Not listed with Underwriters Laboratories, for field installation.
- ⑫ Pigtail wire size: 18 AWG (0.82 mm²).
- ⑬ 125 volts (Max.), 50/60 Hz switch for use in electronic circuit of 100 micro amperes and 15 Vdc minimum.
- ⑭ Not for use on 4-pole circuit breakers.

Table 45-192. K-Frame Electrical Rating Data ⑮⑯

Maximum Voltage	Frequency	Maximum Current Amperes	Dielectric Withstand Voltage
600	50/60 Hz	6	2500
125	dc	0.50 ⑰	
250	dc	0.25 ⑰	

- ⑮ Endurance: 5000 electrical operations plus 1000 mechanical operations.
- ⑯ Pigtail wire size: 18 AWG (0.82 mm²).
- ⑰ Non-inductive load.

Table 45-193. L-Frame Electrical Rating Data ⑰

Maximum Voltage	Frequency	Maximum Current Amperes	Dielectric Withstand Voltage
600	50/60 Hz	6	2500
125	dc	0.50 ⑱	
250	dc	0.25 ⑱	

- ⑰ Pigtail wire size: 18 AWG (0.82 mm²).
- ⑱ Non-inductive load.

Auxiliary Switch

Table 45-196. J-Frame and HMCP (J) Auxiliary Switch

Number of Sets of Contacts a and b	Mounting Location (Pole)	Factory Mounted								Field Mounted			
		Connection Type and Location								Field Installation Kits ①			
		18-Inch (457.2 mm) Pigtail Leads						Terminal Block		Pigtail Leads		Terminal Block	
		Same Side		Rear ②		Opposite Side		Same Side		Catalog Number	Price U.S. \$	Catalog Number	Price U.S. \$
Suffix Number	Adder U.S. \$	Suffix Number	Adder U.S. \$	Suffix Number	Adder U.S. \$	Suffix Number	Adder U.S. \$						
1	Left Right ②	A01 A05		A02 A06		A03 A07		A04 A08		A1X2PK A1X2PK		A1X2LTK A1X2RTK ③	
2	Left Right ②	A09 A12		A10 A13		— —		A11 A14		A2X2PK A2X2PK		A2X2LTK A2X2RTK ③	

- ① Listed with Underwriters Laboratories for field installation or interchangeable trip unit breakers under E64983.
- ② Standard mounting location — leads exit rear of breaker.
- ③ Not for use on 4-pole circuit breakers.

Table 45-197. K-Frame and HMCP (K) Auxiliary Switch

Number of Sets of Contacts a and b	Mounting Location (Pole)	Factory Mounted								Field Mounted			
		Connection Type and Location								Field Installation Kits ④			
		18-Inch (457.2 mm) Pigtail Leads						Terminal Block		Pigtail Leads		Terminal Block	
		Same Side		Rear ⑤		Opposite Side		Same Side		Catalog Number	Price U.S. \$	Catalog Number	Price U.S. \$
Suffix Number	Adder U.S. \$	Suffix Number	Adder U.S. \$	Suffix Number	Adder U.S. \$	Suffix Number	Adder U.S. \$						
1	Left Right ⑥⑦	A01 A05		A02 A06		A03 A07		A04 A08		A1X3PK A1X3PK		A1X3LTK A1X3RTK ⑦	
2	Left Right ⑥⑦	A09 A12		A10 A13		— —		A11 A14		A2X3PK A2X3PK		A2X3LTK A2X3RTK ⑦	
3	Left Right ⑥	A18 A17		— —		— —		A15 A16		A3X3LPK A3X3RPK		A3X3LTK A3X3RTK ⑦	

- ④ Listed with Underwriters Laboratories for field installation under E64983.
- ⑤ Standard mounting location — leads exit rear of breaker.
- ⑥ Breakers with K-Frame OPTIM 550 can only accept accessories in left pole.
- ⑦ Not for use on 4-pole circuit breaker.

Table 45-198. L-Frame and HMCP (L) Auxiliary Switch

Number of Sets of Contacts a and b	Mounting Location (Pole)	Factory Mounted								Field Mounted			
		Connection Type and Location								Field Installation Kits ⑧			
		18-Inch (457.2 mm) Pigtail Leads						Terminal Block		Pigtail Leads		Terminal Block	
		Same Side		Rear ⑨		Opposite Side		Same Side		Catalog Number	Price U.S. \$	Catalog Number	Price U.S. \$
Suffix Number	Adder U.S. \$	Suffix Number	Adder U.S. \$	Suffix Number	Adder U.S. \$	Suffix Number	Adder U.S. \$						
1	Left Right ⑩	A01 A05		A02 A06		A03 A07		A04 A08		A1X4PK A1X4PK		A1X4LTK A1X4RTK ⑩	
2	Left Right ⑩	A09 A12		A10 A13		— —		A11 A14		A2X4PK A2X4PK		A2X4LTK A2X4RTK ⑩	
3	Left Right ⑩	A18 A17		— —		— —		A15 A16		A3X4PK A3X4PK		A3X4LTK A3X4RTK ⑩	

- ⑧ Listed with Underwriters Laboratories for field installation under E64983.
- ⑨ Standard mounting location — leads exit rear of breaker.
- ⑩ Not for use on 4-pole circuit breaker.

Auxiliary Switch and Alarm Switch Combination

Auxiliary Switch and Alarm Switch Combination

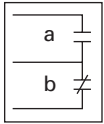

Each Catalog Number listed in Tables 45-199 – 45-206 includes one Auxiliary Switch and one Alarm Switch. In an auxiliary switch ASL switch combination, the auxiliary switch is always mounted on the side of the plug-in module next to the center pole of the circuit breaker.

Table 45-199. F-Frame Electrical Rating Data ^{①②}

Maximum Voltage	Frequency	Maximum Current Amperes	Dielectric Withstand Voltage
600	50/60 Hz	6	2500
125	dc	0.50 ^③	2200
250	dc	0.25 ^③	2200

- ① Endurance: 6000 electrical operations plus 4000 mechanical operations.
 ② Pigtail wire size: 18 AWG (0.82 mm²).
 ③ Non-inductive load.

Table 45-200. J-Frame Electrical Rating Data ^{④⑤}

Maximum Voltage	Frequency	Maximum Current Amperes	Dielectric Withstand Voltage
600	50/60 Hz	6	2500
125	dc	0.50 ^⑥	
250	dc	0.25 ^⑥	

- ④ Endurance: 6000 electrical operations plus 2000 mechanical operations.
 ⑤ Pigtail wire size: 18 AWG (0.82 mm²).
 ⑥ Non-inductive load.

Table 45-201. K-Frame Electrical Rating Data ^{⑦⑧}

Maximum Voltage	Frequency	Maximum Current Amperes	Dielectric Withstand Voltage
600	50/60 Hz	6	2500
125	dc	0.50 ^⑨	
250	dc	0.25 ^⑨	

- ⑦ Endurance: 5000 electrical operations plus 1000 mechanical operations.
 ⑧ Pigtail wire size: 18 AWG (0.82 mm²).
 ⑨ Non-inductive load.

Table 45-202. L-Frame Electrical Rating Data ^{⑩⑪}

Maximum Voltage	Frequency	Maximum Current Amperes	Dielectric Withstand Voltage
600	50/60 Hz	6	2500
125	dc	0.50 ^⑫	
250	dc	0.25 ^⑫	

- ⑩ Endurance: 5000 electrical operations plus 1000 mechanical operations.
 ⑪ Pigtail wire size: 18 AWG (0.82 mm²).
 ⑫ Non-inductive load.

Auxiliary Switch and Alarm Switch Combination

Table 45-203. F-Frame and HMCP (F) Auxiliary Switch and Alarm Switch Combination

Mounting Location (Pole)	Factory Mounted						Field Mounted				
	Connection Type and Location						Field Installation Kits ^{①②}				
	18-Inch (457 mm) Pigtail Leads				Terminal Block		Pigtail Leads		Terminal Block		
	Same Side		Rear ^③		Same Side						
Suffix Number	Adder U.S. \$	Suffix Number	Adder U.S. \$	Suffix Number	Adder U.S. \$	Suffix Number	Adder U.S. \$	Catalog Number	Price U.S. \$	Catalog Number	Price U.S. \$
Left ^③	C01		C02		C03			AAL1LPK		AAL1LTK	
Right	C04		C05		C06			AAL1RPK		AAL1RTK ^④	

- ① Not listed with Underwriters Laboratories for field installation.
- ② For F-Frame HMCP, add an "M" to beginning of catalog number.
- ③ Standard mounting location.
- ④ Not for use on 4-pole circuit breakers.

Table 45-204. J-Frame and HMCP (J) Auxiliary Switch and Alarm Switch Combination

Number of Sets of Contacts (1a and 1b) (1m – 1b)	Mounting Location (Pole)	Factory Mounted						Field Mounted					
		Connection Type and Location						Field Installation Kits ^⑤					
		18-Inch (457 mm) Pigtail Leads				Terminal Block		Pigtail Leads		Terminal Block			
		Same Side		Rear ^⑥		Opposite Side		Same Side					
Suffix Number	Adder U.S. \$	Suffix Number	Adder U.S. \$	Suffix Number	Adder U.S. \$	Suffix Number	Adder U.S. \$	Suffix Number	Adder U.S. \$	Catalog Number	Price U.S. \$	Catalog Number	Price U.S. \$
1	Left Right ^⑥	C01		C02		—		C03		AAL2LPK		AAL2LTK	
		C04		C05		—		C06		AAL2RPK		AAL2RTK ^⑦	

- ⑤ Listed with Underwriters Laboratories for field installation of interchangeable trip unit breakers under E64983.
- ⑥ Standard mounting location — leads exit rear of breaker.
- ⑦ Not for use on 4-pole circuit breakers.

Table 45-205. K-Frame and HMCP (K) Auxiliary Switch and Alarm Switch Combination

Number of Sets of Contacts (1a and 1b) (1m – 1b)	Mounting Location (Pole)	Factory Mounted						Field Mounted					
		Connection Type and Location						Field Installation Kits ^⑧					
		18-Inch (457 mm) Pigtail Leads				Terminal Block		Pigtail Leads		Terminal Block			
		Same Side		Rear ^⑨		Opposite Side		Same Side					
Suffix Number	Adder U.S. \$	Suffix Number	Adder U.S. \$	Suffix Number	Adder U.S. \$	Suffix Number	Adder U.S. \$	Suffix Number	Adder U.S. \$	Catalog Number	Price U.S. \$	Catalog Number	Price U.S. \$
1	Left Right ^⑩	C01		C02		—		C03		AAL3LPK		AAL3LTK	
		C04		C05		—		C06		AAL3RPK ^⑪		AAL3RTK	

- ⑧ Listed with Underwriters Laboratories for field installation of interchangeable trip unit breakers under E64983.
- ⑨ Standard mounting location — leads exit rear of breaker.
- ⑩ Breakers with K-Frame OPTIM 550 can only accept accessories in left pole.
- ⑪ Will not install on OPTIM Trip (RH).

Table 45-206. L-Frame and HMCP (L) Auxiliary Switch and Alarm Switch Combination

Number of Sets of Contacts	Mounting Location (Pole)	Factory Mounted						Field Mounted					
		Connection Type and Location						Field Installation Kits ^⑫					
		18-Inch (457.2 mm) Pigtail Leads				Terminal Block		Pigtail Leads		Terminal Block			
		Same Side		Rear ^⑬		Opposite Side		Same Side					
Suffix Number	Adder U.S. \$	Suffix Number	Adder U.S. \$	Suffix Number	Adder U.S. \$	Suffix Number	Adder U.S. \$	Suffix Number	Adder U.S. \$	Catalog Number	Price U.S. \$	Catalog Number	Price U.S. \$
1A, 1B and 1 Make/1 Break	Left Right ^⑭	C01		C02		—		C03		AA114LPK		AA114LTK	
		C04		C05		—		C06		AA114RPK		AA114RTK ^⑮	
2A, 2B and 1 Make/1 Break	Left Right ^⑭	C07		C08		—		C12		AA214LPK		AA214LTK	
		C10		C11		—		C13		AA214RPK		AA214RTK ^⑮	
3A, 3B and 1 Make/1 Break	Left Right ^⑭	C14		—		—		—		AA314LPK		—	
		C15		—		—		—		AA314RPK		—	

- ⑫ Listed with Underwriters Laboratories for field installation under E64983.
- ⑬ Standard mounting location — leads exit rear of breaker.
- ⑭ Not for use on 4-pole circuit breaker.

Shunt Trip

Shunt Trip

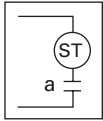

The Shunt Trip provides remote controlled tripping of the circuit breaker. The shunt trip consists of an intermittent rated solenoid with a tripping plunger and a cutoff switch assembled to a plug-in module. When required for ground

fault protection applications, certain ac rated shunt trips, as noted in the Electrical Rating Table, are suitable for operation at 55 percent of rated voltage.

Select shunt trip catalog number for the voltage within the indicated voltage range. Shunt trip coils are designed to be applied at specific ac or dc voltages within the voltage range shown. Electrical ratings are also shown on applicable circuit breaker accessory nameplates.

Table 45-207. F-Frame Electrical Rating Data ①②③

50/60 Hz			dc		
Supply Voltage	Minimum Operating Voltage	VA	Supply Voltage	Minimum Operating Voltage	VA
12 24	6.75	75 300	12 24	9	100 400
48 60	36	92 140	48 60	36	100 160
110 120 127 208 220 240	156	480 570 640 180 200 240	110 120 125	77	55 66 71
380 415 440	300	610 130 330	127 220 250	—	72 110 140
480 525 550 600	300	380 450 530 590	— — — —	— — — —	— — — —

- ① Average unlatching time: 6 milliseconds.
 ② Average circuit breaker contact total opening time: 18 milliseconds.
 ③ Endurance: 6000 electrical operations plus 4000 mechanical operations.

Table 45-208. J-Frame Electrical Rating Data ④⑤⑥

50/60 Hz			dc		
Supply Voltage	Minimum Operating Voltage	VA	Supply Voltage	Minimum Operating Voltage	VA
12 24	9	31 173	12 24	8.4	50 247
48 60	36	686 1014	48 60	33.6	1094 1698
110 ⑦ 120 ⑦ 127 ⑦ 208 ⑦ 220 ⑦ 240 ⑦	60.5	66 84 102 354 396 432	110 120 125	77	112 138 150
380 400 415 440	285	180 200 240 610	110 120 125 127	154	40 58
480 525 550 600	360	34 42 — 60	— — — —	— — — —	— — — —

- ④ Average unlatching time: 6 milliseconds.
 ⑤ Average circuit breaker contact total opening time: 18 milliseconds.
 ⑥ Endurance: 6000 electrical operations plus 2000 mechanical operations.
 ⑦ Supply voltages suitable for use with Class 1 GFP devices. Marking label included with accessory kits.

Table 45-209. K-Frame Electrical Rating Data ⑧⑨⑩

50/60 Hz			dc		
Supply Voltage	Minimum Operating Voltage	VA	Supply Voltage	Minimum Operating Voltage	VA
12 24	9	45 200	12 24	8.4	35 170
48 60		830 1280	48 60		710 1105
110 ⑪ 120 ⑪ 127 ⑪ 208 ⑪ 220 ⑪ 240 ⑪	60	100 120 140 420 470 550	110 120 125	77	110 130 140
380 400 415 440	285	95 108 120 136	220 250	154	41 54
480 525 550 600	360	40 50 50 70	— — — —	— — — —	— — — —

- ⑧ Approximate unlatching time: 6 milliseconds.
 ⑨ Approximate total circuit breaker contact opening time: 8 milliseconds.
 ⑩ Endurance: 5,000 electrical operations plus 1,000 mechanical operations.
 ⑪ Supply voltages suitable for use with Class 1 GFP devices. Marking label included with accessory kits.

Table 45-210. L-Frame Electrical Rating Data ⑫⑬⑭

50/60 Hz			dc		
Supply Voltage	Minimum Operating Voltage	VA	Supply Voltage	Minimum Operating Voltage	VA
12 24	9	45 200	12 24	9	35 170
48 60	34	830 1280	48 60	34	710 1105
110 ⑮ 120 ⑮ 127 ⑮ 208 ⑮ 220 ⑮ 240 ⑮	60	100 120 140 420 470 550	110 120 125	77	110 130 140
380 400 415 440	266	95 108 120 136	220 250	154	41 54
480 525 550 600	336	40 50 50 70	— — — —	— — — —	— — — —

- ⑫ Approximate unlatching time: 6 milliseconds.
 ⑬ Approximate total circuit breaker contact opening time: 18 milliseconds.
 ⑭ Endurance: 5,000 electrical operations plus 1,000 mechanical operations.
 ⑮ Supply voltages suitable for use with Class 1 GFP devices. Marking label included with accessory kits.

Shunt Trip

Table 45-211. G-Frame Shunt Trip (LH 3-Pole only)

Electrical Ratings			Suffix Number	Adder U.S. \$	Catalog Number	Price U.S. \$
Volts	Frequency	Amperes				
120	50/60 Hz	1.1	S1		1373D62G01	
240	50/60 Hz	2.1	S2		1373D62G02	
12	dc	2.8	S3		1373D62G15	
24	dc	5.7	S4		1373D62G16	
24	60 Hz	—	S7		1373D62G20	

Note: G-Frame circuit breakers are factory sealed. Underwriters Laboratories requires that internal accessories be installed at the factory.

Note: Internal accessories are UL listed for factory installation under E7819.

Note: Where local codes and standards permit and UL listing is not required, internal accessories can be field installed. Accessory installation should be done before the circuit breaker is mounted and connected.

Table 45-212. F-Frame and HMCP (F) Shunt Trip

Voltage Rating (ac Frequency = 50/60 Hz)	Factory Mounted								Field Mounted			
	Connection Type and Location								Field Installation Kits ①			
	18-Inch (457.2 mm) Pigtail Leads ②						Terminal Block		Pigtail Leads		Terminal Block	
	Same Side		Rear ③		Opposite Side		Same Side					
Suffix Number	Adder U.S. \$	Suffix Number	Adder U.S. \$	Suffix Number	Adder U.S. \$	Suffix Number	Adder U.S. \$	Catalog Number	Price U.S. \$	Catalog Number	Price U.S. \$	

Left-Pole Mounting ac/dc Ratings

12 – 24 Vac or dc	S01		S02		S03		S04		SNT1LP03K		SNT1LT03K	
48 – 127 Vac or 48 – 60 Vdc ④	S05		S06		S07		S08		SNT1LP08K		SNT1LT08K	
208 – 380 Vac or 110 – 127 Vdc	S09		S10		S11		S12		SNT1LP12K		SNT1LT12K	
415 – 600 Vac or 220 – 250 Vdc	S13		S14		S15		S16		SNT1LP18K		SNT1LT18K	

Right- or Neutral-Pole Mounting ac/dc Ratings ⑤

12 – 24 Vac or dc	S17		S18		S19		S20		SNT1RP03K		SNT1RT03K ⑥	
48 – 127 Vac or 48 – 60 Vdc ④	S21		S22		S23		S24		SNT1RP08K		SNT1RT08K ⑥	
208 – 380 Vac or 110 – 127 Vdc	S25		S26		S27		S28		SNT1RP12K		SNT1RT12K ⑥	
415 – 600 Vac or 220 – 250 Vdc	S29		S30		S31		S32		SNT1RP18K		SNT1RT18K ⑥	

① Not listed with Underwriters Laboratories, for field installation.

② Pigtail wire size: 18 AWG (0.82 mm²).

③ Standard pigtail lead exit location.

④ 120 Vac marked suitable for ground fault protection devices.

⑤ Standard mounting location.

⑥ Not for use on 4-pole circuit breakers

Table 45-213. J-Frame and HMCP (J) Shunt Trip

Voltage Rating (ac Frequency = 50/60 Hz)	Factory Mounted								Field Mounted			
	Connection Type and Location								Field Installation Kits ②			
	18-Inch (457.2 mm) Pigtail Leads						Terminal Block		Pigtail Leads		Terminal Block	
	Same Side		Rear ③		Opposite Side		Same Side					
Suffix Number	Adder U.S. \$	Suffix Number	Adder U.S. \$	Suffix Number	Adder U.S. \$	Suffix Number	Adder U.S. \$	Catalog Number	Price U.S. \$	Catalog Number	Price U.S. \$	

Left-Pole Mounting ac/dc Ratings ④

12 – 24 Vac or dc	S41		S42		S43		S44		SNT2P04K		SNT2T04K	
48 – 60 Vac or dc	S49		S50		S51		S52		SNT2P06K		SNT2T06K	
110 – 240 Vac or 110 – 125 Vdc ⑤	S09		S10		S11		S12		SNT2P11K		SNT2T11K	
380 – 440 Vac or 220 – 250 Vdc	S13		S14		S15		S16		SNT2P14K		SNT2T14K	
480 – 600 Vac	S17		S18		S19		S20		SNT2P18K		SNT2T18K	

Right- or Neutral-Pole Mounting ac/dc Ratings

12 – 24 Vac or dc	S45		S46		S47		S48		SNT2P04K		SNT2T04K ⑥	
48 – 60 Vac or dc	S53		S54		S55		S56		SNT2P06K		SNT2T06K ⑥	
110 – 240 Vac or 110 – 125 Vdc ⑤	S29		S30		S31		S32		SNT2P11K		SNT2T11K ⑥	
380 – 440 Vac or 220 – 250 Vdc	S33		S34		S35		S36		SNT2P14K		SNT2T14K ⑥	
480 – 600 Vac	S37		S38		S39		S40		SNT2P18K		SNT2T18K ⑥	

② Listed with Underwriters Laboratories for field installation under E64983.

③ Standard mounting location — leads exit rear of breaker.

④ Suitable for use with Class 1 ground fault sensing element.

⑥ Not for use on 4-pole circuit breakers.

Shunt Trip

Table 45-214. K-Frame and HMCP (K) Shunt Trip

Voltage Rating (ac Frequency = 50/60 Hz)	Factory Mounted								Field Mounted			
	Connection Type and Location								Field Installation Kits ^①			
	18-Inch (457.2 mm) Pigtail Leads						Terminal Block		Pigtail Leads		Terminal Block	
	Same Side		Rear ^②		Opposite Side		Same Side					
Suffix Number	Adder U.S. \$	Suffix Number	Adder U.S. \$	Suffix Number	Adder U.S. \$	Suffix Number	Adder U.S. \$	Catalog Number	Price U.S. \$	Catalog Number	Price U.S. \$	

Left-Pole Mounting ac/dc Ratings ^②

12 – 24 Vac or dc	S41		S42		S43		S44		SNT3P04K		SNT3T04K	
48 – 60 Vac or dc	S49		S50		S51		S52		SNT3P06K		SNT3T06K	
110 – 240 Vac or 110 – 125 Vdc ^③	S09		S10		S11		S12		SNT3P11K		SNT3T11K	
380 – 440 Vac or 220 – 250 Vdc	S33		S34		S35		S36		SNT3P14K		SNT3T14K	
480 – 600 Vac	S17		S18		S19		S20		SNT3P18K		SNT3T18K	

Right- or Neutral-Pole Mounting ac/dc Ratings ^{④⑤}

12 – 24 Vac or dc	S45		S46		S47		S48		SNT3P04K		SNT3T04K ^⑥	
48 – 60 Vac or dc	S53		S54		S55		S56		SNT3P06K		SNT3T06K ^⑥	
110 – 240 Vac or 110 – 125 Vdc ^③	S29		S30		S31		S32		SNT3P11K		SNT3T11K ^⑥	
380 – 440 Vac or 220 – 250 Vdc	S33		S34		S35		S36		SNT3P14K		SNT3T14K ^⑥	
480 – 600 Vac	S37		S38		S39		S40		SNT3P18K		SNT3T18K ^⑥	

^① Listed with Underwriters Laboratories, for field installation under E64983.

^② Standard mounting location — leads exit rear of breaker.

^③ Suitable for use with Class 1 ground fault sensing element.

^④ For use with KT (thermal-magnetic) trip units only.

^⑤ Breakers with K-Frame OPTIM 550 can only accept accessories in left pole.

^⑥ Not for use on 4-pole circuit breaker.

Table 45-215. L-Frame and HMCP (L) Shunt Trip

Voltage Rating (ac Frequency = 50/60 Hz)	Factory Mounted								Field Mounted			
	Connection Type and Location								Field Installation Kits ^①			
	18-Inch (457.2 mm) Pigtail Leads						Terminal Block		Pigtail Leads		Terminal Block	
	Same Side		Rear ^②		Opposite Side		Same Side					
Suffix Number	Adder U.S. \$	Suffix Number	Adder U.S. \$	Suffix Number	Adder U.S. \$	Suffix Number	Adder U.S. \$	Catalog Number	Price U.S. \$	Catalog Number	Price U.S. \$	

Left-Pole Mounting ac/dc Ratings ^②

12 – 24 Vac or dc	S01		S02		S03		S04		SNT4LP03K		SNT4LT03K	
48 – 60 Vdc	S05		S06		S07		S08		SNT4LP05K		SNT4LT05K	
48 – 60 Vdc	S85		S86		S87		—		SNT4LP23K		SNT4LT23K	
110 – 240 Vac	S09		S10		S11		S12		SNT4LP11K		SNT4LT11K	
110 – 125 Vdc	S41		S42		S43		S44		SNT4LP26K		SNT4LT26K	
380 – 440 Vac or 220 – 250 Vdc	S13		S14		S15		S16		SNT4LP14K		SNT4LT14K	
480 – 600 Vac	S17		S18		S19		S20		SNT4LP18K		SNT4LT18K	

Right-Pole Mounting ac/dc Ratings ^②

12 – 24 Vac or dc	S21		S22		S23		S24		SNT4RP03K		SNT4RT03K	
48 – 60 Vdc	S25		S26		S27		S28		SNT4RP05K		SNT4RT05K	
48 – 60 Vdc	S88		S89		S90		—		SNT4RP23K		SNT4RT23K	
110 – 240 Vac	S29		S30		S31		S32		SNT4RP11K		SNT4RT11K	
110 – 125 Vdc	S45		S46		S47		S48		SNT4RP26K		SNT4RT26K	
380 – 440 Vac or 220 – 250 Vdc	S33		S34		S35		S36		SNT4RP14K		SNT4RT14K	
480 – 600 Vac	S37		S38		S39		S40		SNT4RP18K		SNT4RT18K	

^① Listed with Underwriters Laboratories, for field installation under E64983.

^② Standard mounting location — leads exit rear of breaker.

^③ For use with LT (thermal-magnetic) 3-pole trip units only.

Low Energy Shunt Trip

Low Energy Shunt Trip

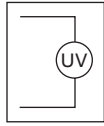

Low Energy Shunt Trip devices are designed to operate from low energy output signals from dedicated current sensors typically applied in ground

fault protection schemes. However, with a proper control voltage source, they may be applied in place of conventional trip devices for special applications. Flux paths surrounding permanent magnets used in the shunt trip assembly hold a charged spring poised in readiness to operate the circuit breaker trip mechanism.

When a 100 microfarad capacitor charged to 28 Vdc is discharged through the shunt trip coil, the resultant flux opposes the permanent magnet flux field, which releases the stored energy in the spring to trip the circuit breaker. As the circuit breaker resets, the shunt trip reset arm is actuated by the circuit breaker handle, resetting the shunt trip. The plug-in module is mounted in retaining slots in the top of the trip unit. Coil is intermittent-rated only. Cutoff provisions required in control circuit.

Ordering Information

Select shunt trip catalog number for the voltage within the indicated voltage range. Shunt trip coils are designed to be applied at specific ac or dc voltages within the voltage range shown. Electrical ratings are also shown on applicable circuit breaker accessory nameplates.

Table 45-216. F-, J-, K- and L-Frames and HMCPs Low Energy Shunt Trip ①

Mounting Positions (Pole)	Factory Mounted								Field Mounted			
	Connection Type and Location								Field Installation Kits ②			
	18-Inch (457.2 mm) Pigtail Leads						Terminal Block		Pigtail Leads		Terminal Block	
	Same Side		Rear ③		Opposite Side		Same Side		Catalog Number	Price U.S. \$	Catalog Number	Price U.S. \$
Suffix Number	Adder U.S. \$	Suffix Number	Adder U.S. \$	Suffix Number	Adder U.S. \$	Suffix Number	Adder U.S. \$					
F-Frame												
Left	NO1		NO2		NO3		NO4		LST1LPK ④		LST1LTK ④	
Right ③	NO5		NO6		NO7		NO8		LST1RPK ④		LST1RTK ④	
J-Frame												
Left	NO1		NO2		NO3		—		LST2LPK		—	
Right ③	NO5		NO6		NO7		—		LST2RPK		—	
K-Frame												
Left ③	NO1		NO2		NO3		—		LST3LPK		—	
Right ⑤⑥	NO5		NO6		NO7		—		LST3RPK		—	
L-Frame												
Left	NO1		NO2		NO3		—		LST4LPK		—	
Right	NO5		NO6		NO7		—		LST4RPK		—	

- ① Cutoff provisions required in control circuit.
- ② Listed with Underwriters Laboratories for field installation under E64983.
- ③ Standard mounting location — leads exit rear of breaker.
- ④ For F-Frame HMCP, add an "M" to beginning of catalog number.
- ⑤ For use with thermal-magnetic trip units only.
- ⑥ Breakers with K-Frame OPTIM 550 can only accept accessories in left pole.

Undervoltage Release Mechanism

Undervoltage Release Mechanism

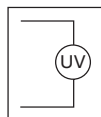

The Undervoltage Release Mechanism monitors a voltage (typically a line voltage) and trips the circuit breaker when the voltage falls to between 70 and 35 percent of the solenoid coil rating.

The undervoltage release mechanism consists of a continuous rated solenoid with a plunger and tripping lever mounted in a plug-in module. The tab on the tripping lever resets the undervoltage release mechanism when normal voltage has been restored and the circuit breaker handle is moved to the reset (or OFF) position. With less than pickup voltage applied to the undervoltage release mechanism, the circuit breaker contacts will not touch when a closing operation is attempted.

Note: Undervoltage release mechanism accessories are not designed for, and should not be used as, circuit interlocks.

Ordering Information

Select handle reset undervoltage release mechanism catalog number for the voltage within the indicated voltage range. Undervoltage release mechanism coils are designed to be applied at specific ac or dc voltages within the voltage range shown on applicable circuit breaker accessory nameplates.

Table 45-217. F-Frame Electrical Rating Data ^①

50/60 Hz					dc				
Supply Voltage	Dropout Voltage		Pickup Voltage	VA	Supply Voltage	Dropout Voltage		Pickup Voltage	VA
	Minimum	Maximum	Maximum			Minimum	Maximum	Maximum	
12	4.2	6.3	7.6	1.3 2.5	12	4.2	8.4	10.2	2.8
24	8.4	16.8	20.4	1.4	24	8.4	16.8	20.4	1.6
48 60	21.0	33.6	40.8	1.2 1.9	48 60	21.0	33.6	40.8	1.3 2.0
110 120 127	44.5	77.0	93.5	1.3 1.5 1.7	110 120 125	44.5	77.0	93.5	1.5 1.7 1.9
208 220 240	84.0	145.6	176.8	2.2 2.4 2.9	220 250	87.5	154.0	187.0	2.6 3.4 —
380 415 440 480	168.0	266.0	323.0	2.9 3.5 3.9 4.6	—	—	—	—	—
525 550 600	210.0	367.0	446.0	4.3 4.8 5.8	—	—	—	—	—

^① Endurance: 6,000 electrical operations plus 4,000 mechanical operations.

Table 45-218. J-Frame Electrical Rating Data ^{②③}

50/60 Hz					dc				
Supply Voltage	Dropout Voltage		Pickup Voltage	VA	Supply Voltage	Dropout Voltage		Pickup Voltage	VA
	Minimum	Maximum	Maximum			Minimum	Maximum	Maximum	
12	4.2	8.4	10.2	1.9	12	4.2	8.4	10.2	1.6
24	8.4	16.8	20.4	3.9	24	8.4	16.8	20.4	3.1
48 60	21.0	33.6	40.8	2.5 3.8	48 60	21.0	33.6	40.8	2.0 3.1
110 120 127	44.5	77.0	93.5	1.8 2.1 2.4	110 120 125	44.5	77.0	93.5	1.6 1.9 2.2
208 220 240	84.0	145.6	176.8	2.7 3.1 3.8	220 250	87.5	154.0	187.0	3.1 4.0 —
380 415 440 480	168.0	266.0	323.0	3.4 4.0 4.6 5.4	—	—	—	—	—

^② Endurance: 6,000 electrical operations plus 2,000 mechanical operations.

^③ For electrical rating data for manual, automatic and electrical reset undervoltage release mechanisms, refer to Eaton.

Undervoltage Release Mechanism

Table 45-219. K-Frame Electrical Rating Data ①

50/60 Hz					dc				
Supply Voltage	Dropout Voltage		Pickup Voltage	VA	Supply Voltage	Dropout Voltage		Pickup Voltage	VA
	Minimum	Maximum	Maximum			Minimum	Maximum	Maximum	
12	4.2	8.4	10.2	1.9	12	4.2	8.4	10.2	1.6
24	8.4	16.8	20.4	3.9	24	8.4	16.8	20.4	3.1
48	21.0	33.6	40.8	2.5	48	21.0	33.6	40.8	2.0
60				3.8	60				3.1
110	44.5	77.0	93.5	1.8	110	44.5	77.0	93.5	1.6
120				2.1	120				1.9
127				2.4	125				2.2
208	84.0	145.6	176.8	2.7	220	87.5	154.0	187.0	3.1
220				3.1	250				4.0
240				3.8	—				—
380	168.0	266.0	323.0	3.4	—	—	—	—	—
415				4.0	—				—
440				4.6	—				—
480				5.4	—				—
				—	—				—

① Endurance: 5,000 electrical operations plus 1,000 mechanical operations.

Table 45-220. L-Frame Electrical Rating Data ②

50/60 Hz					dc				
Supply Voltage	Dropout Voltage		Pickup Voltage	VA	Supply Voltage	Dropout Voltage		Pickup Voltage	VA
	Minimum	Maximum	Maximum			Minimum	Maximum	Maximum	
12	4.2	8.4	10.2	1.9	12	4.2	8.4	10.2	1.6
24	8.4	16.8	20.4	3.9	24	8.4	16.8	20.4	3.1
48	21.0	33.6	40.8	2.5	48	21.0	33.6	40.8	2.0
60				3.8	60				3.1
110	44.5	77.0	93.5	1.8	110	44.5	77.0	93.5	1.6
120				2.1	120				1.9
127				2.4	125				2.2
208	84.0	145.6	176.8	2.7	220	87.5	154.0	187.0	3.1
220				3.1	250				4.0
240				3.8	—				—
380	168.0	266.0	323.0	3.4	—	—	—	—	—
415				4.0	—				—
440				4.6	—				—
480				5.4	—				—
				—	—				—

② Endurance: 5,000 electrical operations plus 1,000 mechanical operations.

Undervoltage Release Mechanism

Table 45-221. G-Frame Undervoltage Release Mechanism (LH 3-Pole only)

Electrical Ratings			Style Numbers ①②③	Price U.S. \$	Factory Suffix	Adder U.S. \$
Volts (ac Only)	Frequency	Amperes				
120	50/60 Hz	0.05	1373D62G03		T1	
24	50/60 Hz	0.22	1373D62G04		T2	
48	50/60 Hz	0.11	1373D62G05		T3	
60	50/60 Hz	0.10	1373D62G06		T4	
110	50 Hz	0.049	1373D62G07		T5	
208	60 Hz	0.026	1373D62G08		T6	
220	50 Hz	0.025	1373D62G09		T7	
240	50/60 Hz	0.024	1373D62G10		T8	
380	50 Hz	0.015	1373D62G11		T9	
415	50 Hz	0.013	1373D62G12		T10	
440	50 Hz	0.012	1373D62G13		T11	
480	60 Hz	0.01	1373D62G14		T12	

- ① Includes 24-inch (609.6 mm) external pigtail leads, 18 AWG (16-.010).
- ② A maximum of two internal accessories may be mounted in a 3-pole circuit breaker.
- ③ Suitable for mounting in left pole only of 3-pole breaker.

Note: G-frame circuit breakers are factory sealed. Underwriters Laboratories, requires that internal accessories be installed at the factory.

Note: Internal accessories are UL listed for factory installation under E7819.

Note: Where local codes and standards permit and UL listing is not required, internal accessories can be field installed. Accessory installation should be done before the circuit breaker is mounted and connected.

Table 45-222. F-Frame Factory Mounted (For F-Frame Breaker and F-Frame HMCP) Undervoltage Release Mechanism

Voltage Rating (ac Freq. = 50/60 Hz)	Connection Type and Location							
	18-Inch Pigtail Leads						Terminal Block	
	Same Side		Rear ④		Opposite Side		Same Side	
	Suffix Number	Adder U.S. \$	Suffix Number	Adder U.S. \$	Suffix Number	Adder U.S. \$	Suffix Number	Adder U.S. \$

Left-Pole Mounting ac Ratings

12 Vac	U01		U02		U03		U04	
24 Vac	U05		U06		U07		U08	
48 Vac	U37		U38		U39		U40	
60 Vac	U97		U98		U99		U100	
110 – 127 Vac	U13		U14		U15		U16	
208 – 240 Vac	U17		U18		U19		U20	
380 – 480 Vac	U21		U22		U23		U24	
525 – 600 Vac	U25		U26		U27		U28	

Right-Pole Mounting ac Ratings ⑤⑥

12 Vac	U49		U50		U51		U52	
24 Vac	U53		U54		U55		U56	
48 Vac	U85		U86		U87		U88	
60 Vac	U101		U102		U103		U104	
110 – 127 Vac	U61		U62		U63		U64	
208 – 240 Vac	U65		U66		U67		U68	
380 – 480 Vac	U69		U70		U71		U72	
525 – 600 Vac	U73		U74		U75		U76	

Left-Pole Mounting dc Ratings

12 Vdc	U29		U30		U31		U32	
24 Vdc	U33		U34		U35		U36	
48 Vdc	U37		U38		U39		U40	
60 Vdc	U97		U98		U99		U100	
110 – 127 Vdc	U41		U42		U43		U44	
220 – 250 Vdc	U45		U46		U47		U48	

Right-Pole Mounting dc Ratings ⑤⑥

12 Vdc	U77		U78		U79		U80	
24 Vdc	U81		U82		U83		U84	
48 Vdc	U85		U86		U87		U88	
60 Vdc	U101		U102		U103		U104	
110 – 127 Vdc	U89		U90		U91		U92	
220 – 250 Vdc	U93		U94		U95		U96	

- ④ Standard pigtail lead exit location.
- ⑤ Standard mounting location.
- ⑥ Not for use on right pole of 4-pole circuit breaker.

Note: F-frame circuit breakers are factory sealed. Underwriters Laboratories, requires that internal accessories be installed at the factory.

Note: Internal accessories are UL listed for factory installation under E7819.

Note: Where local codes and standards permit and UL listing is not required, internal accessories can be field installed. Accessory installation should be done before the circuit breaker is mounted and connected.

Undervoltage Release Mechanism

Table 45-223. F-Frame Field Mounted Undervoltage Release Mechanism

Voltage Rating (ac Freq. = 50/60 Hz)	F-Frame Breaker				F-Frame Breaker HMCP			
	Field Installation Kits ①							
	Pigtail Leads		Terminal Block		Pigtail Leads		Terminal Block	
	Catalog Number	Price U.S. \$	Catalog Number	Price U.S. \$	Catalog Number	Price U.S. \$	Catalog Number	Price U.S. \$
Left-Pole Mounting ac Ratings								
12 Vac	UVH1LP02K		UVH1LT02K		MUVH1LP02K		MUVH1LT02K	
24 Vac	UVH1LP03K		UVH1LT03K		MUVH1LP03K		MUVH1LT03K	
48 Vac	UVH1LP22K		UVH1LT22K		MUVH1LP22K		MUVH1LT22K	
60 Vac	UVH1LP24K		UVH1LT24K		MUVH1LP24K		MUVH1LT24K	
110 – 127 Vac	UVH1LP08K		UVH1LT08K		MUVH1LP08K		MUVH1LT08K	
208 – 240 Vac	UVH1LP11K		UVH1LT11K		MUVH1LP11K		MUVH1LT11K	
380 – 480 Vac	UVH1LP15K		UVH1LT15K		MUVH1LP15K		MUVH1LT15K	
525 – 600 Vac	UVH1LP18K		UVH1LT18K		MUVH1LP18K		MUVH1LT18K	
Right-Pole Mounting ac Ratings ②③								
12 Vac	UVH1RP02K		UVH1RT02K		MUVH1RP02K		MUVH1RT02K	
24 Vac	UVH1RP03K		UVH1RT03K		MUVH1RP03K		MUVH1RT03K	
48 Vac	UVH1RP22K		UVH1RT22K		MUVH1RP22K		MUVH1RT22K	
60 Vac	UVH1RP24K		UVH1RT24K		MUVH1RP24K		MUVH1RT24K	
110 – 127 Vac	UVH1RP08K		UVH1RT08K		MUVH1RP08K		MUVH1RT08K	
208 – 240 Vac	UVH1RP11K		UVH1RT11K		MUVH1RP11K		MUVH1RT11K	
380 – 480 Vac	UVH1RP15K		UVH1RT15K		MUVH1RP15K		MUVH1RT15K	
525 – 600 Vac	UVH1RP18K		UVH1RT18K		MUVH1RP18K		MUVH1RT18K	
Left-Pole Mounting dc Ratings								
12 Vdc	UVH1LP20K		UVH1LT20K		MUVH1LP20K		MUVH1LT20K	
24 Vdc	UVH1LP21K		UVH1LT21K		MUVH1LP21K		MUVH1LT21K	
48 Vdc	UVH1LP22K		UVH1LT22K		MUVH1LP22K		MUVH1LT22K	
60 Vdc	UVH1LP24K		UVH1LT24K		MUVH1LP24K		MUVH1LT24K	
110 – 127 Vdc	UVH1LP26K		UVH1LT26K		MUVH1LP26K		MUVH1LT26K	
220 – 250 Vdc	UVH1LP28K		UVH1LT28K		MUVH1LP28K		MUVH1LT28K	
Right-Pole Mounting dc Ratings ②③								
12 Vdc	UVH1RP20K		UVH1RT20K		MUVH1RP20K		MUVH1RT20K	
24 Vdc	UVH1RP21K		UVH1RT21K		MUVH1RP21K		MUVH1RT21K	
48 Vdc	UVH1RP22K		UVH1RT22K		MUVH1RP22K		MUVH1RT22K	
60 Vdc	UVH1RP22K		UVH1RT22K		MUVH1RP22K		MUVH1RT22K	
110 – 127 Vdc	UVH1RP26K		UVH1RT26K		MUVH1RP26K		MUVH1RT26K	
220 – 250 Vdc	UVH1RP28K		UVH1RT28K		MUVH1RP28K		MUVH1RT28K	

① Not listed with Underwriters Laboratories, for field installation.
 ② Standard mounting location.
 ③ Not for use on right pole of 4-pole circuit breaker.

Undervoltage Release Mechanism

Table 45-224. J-Frame and HMCP (J) Undervoltage Release Mechanism

Voltage Rating (ac Freq. = 50/60 Hz)	Factory Mounted							Field Mounted				
	Connection Type and Location							Field Installation Kits ^②				
	18-Inch (457.2 mm) Pigtail Leads						Terminal Block ^①		Pigtail Leads		Terminal Block ^③	
	Same Side		Rear ^②		Opposite Side		Same Side					
Suffix Number	Adder U.S. \$	Suffix Number	Adder U.S. \$	Suffix Number	Adder U.S. \$	Suffix Number	Adder U.S. \$	Catalog Number	Price U.S. \$	Catalog Number	Price U.S. \$	

Left-Pole Mounting ac Ratings ^④

12 Vac	U05		U06		U07		U08		UVH2LP02K		UVH2LT02K	
24 Vac	U09		U10		U11		U12		UVH2LP03K		UVH2LT03K	
48 – 60 Vac	U13		U14		U15		U16		UVH2LP05K		UVH2LT05K	
110 – 127 Vac	U17		U18		U19		U20		UVH2LP08K		UVH2LT08K	
208 – 240 Vac	U21		U22		U23		U24		UVH2LP11K		UVH2LT11K	
380 – 480 Vac	U25		U26		U27		U28		UVH2LP15K		UVH2LT15K	

Right-Pole Mounting ac Ratings ^③

12 Vac	U37		U38		U39		U40		UVH2RP02K		UVH2RT02K	
24 Vac	U41		U42		U43		U44		UVH2RP03K		UVH2RT03K	
48 – 60 Vac	U45		U46		U47		U48		UVH2RP05K		UVH2RT05K	
110 – 127 Vac	U49		U50		U51		U52		UVH2RP08K		UVH2RT08K	
208 – 240 Vac	U53		U54		U55		U56		UVH2RP11K		UVH2RT11K	
380 – 480 Vac	U57		U58		U59		U60		UVH2RP15K		UVH2RT15K	

Left-Pole Mounting dc Ratings ^④

12 Vdc	T01		T02		T03		T04		UVH2LP20K		UVH2LT20K	
24 Vdc	T05		T06		T07		T08		UVH2LP21K		UVH2LT21K	
48 – 60 Vdc	T09		T10		T11		T12		UVH2LP23K		UVH2LT23K	
110 – 127 Vdc	T13		T14		T15		T16		UVH2LP26K		UVH2LT26K	
220 – 250 Vdc	T17		T18		T19		T20		UVH2LP28K		UVH2LT28K	

Right-Pole Mounting dc Ratings ^③

12 Vdc	T21		T22		T23		T24		UVH2RP20K		UVH2RT20K	
24 Vdc	T25		T26		T27		T28		UVH2RP21K		UVH2RT21K	
48 – 60 Vdc	T29		T30		T31		T32		UVH2RP23K		UVH2RT23K	
110 – 127 Vdc	T33		T34		T35		T36		UVH2RP26K		UVH2RT26K	
220 – 250 Vdc	T37		T38		T39		T40		UVH2RP28K		UVH2RT28K	

① For electrical rating data for manual, automatic and electrical reset undervoltage release mechanisms, refer to Eaton.

② Listed with Underwriters Laboratories for field installation under E64983.

③ Not for use on right pole of 4-pole circuit breakers.

④ Standard mounting location — leads exit rear of breaker.

Undervoltage Release Mechanism

Table 45-225. K-Frame and HMCP (K) Undervoltage Release Mechanism

Voltage Rating (ac Freq. = 50/60 Hz)	Factory Mounted								Field Mounted			
	Connection Type and Location								Field Installation Kits ①			
	18-Inch (457.2 mm) Pigtail Leads						Terminal Block		Pigtail Leads		Terminal Block	
	Same Side		Rear ②		Opposite Side		Same Side		Catalog Number	Price U.S. \$	Catalog Number	Price U.S. \$
Suffix Number	Adder U.S. \$	Suffix Number	Adder U.S. \$	Suffix Number	Adder U.S. \$	Suffix Number	Adder U.S. \$					

Left-Pole Mounting ac Ratings ②

12 Vac	U05		U06		U07		U08		UVH3LP02K		UVH3LT02K	
24 Vac	U09		U10		U11		U12		UVH3LP03K		UVH3LT03K	
48 – 60 Vac	U13		U14		U15		U16		UVH3LP05K		UVH3LT05K	
110 – 127 Vac	U17		U18		U19		U20		UVH3LP08K		UVH3LT08K	
208 – 240 Vac	U21		U22		U23		U24		UVH3LP11K		UVH3LT11K	
380 – 480 Vac	U25		U26		U27		U28		UVH3LP15K		UVH3LT15K	

Right-Pole Mounting ac Ratings ③④⑤

12 Vac	U37		U38		U39		U40		UVH3RP02K		UVH3RT02K	
24 Vac	U41		U42		U43		U44		UVH3RP03K		UVH3RT03K	
48 – 60 Vac	U45		U46		U47		U48		UVH3RP05K		UVH3RT05K	
110 – 127 Vac	U49		U50		U51		U52		UVH3RP08K		UVH3RT08K	
208 – 240 Vac	U53		U54		U55		U56		UVH3RP11K		UVH3RT11K	
380 – 480 Vac	U57		U58		U59		U60		UVH3RP15K		UVH3RT15K	

Left-Pole Mounting dc Ratings ②

12 Vdc	T01		T02		T03		T04		UVH3LP20K		UVH3LT20K	
24 Vdc	T05		T06		T07		T08		UVH3LP21K		UVH3LT21K	
48 – 60 Vdc	T09		T10		T11		T12		UVH3LP23K		UVH3LT23K	
110 – 127 Vdc	T13		T14		T15		T16		UVH3LP26K		UVH3LT26K	
220 – 250 Vdc	T17		T18		T19		T20		UVH3LP28K		UVH3LT28K	

Right-Pole Mounting dc Ratings ③④⑤

12 Vdc	T21		T22		T23		T24		UVH3RP20K		UVH3RT20K	
24 Vdc	T25		T26		T27		T28		UVH3RP21K		UVH3RT21K	
48 – 60 Vdc	T29		T30		T31		T32		UVH3RP23K		UVH3RT23K	
110 – 127 Vdc	T33		T34		T35		T36		UVH3RP26K		UVH3RT26K	
220 – 250 Vdc	T37		T38		T39		T40		UVH3RP28K		UVH3RT28K	

- ① Listed with Underwriters Laboratories, for field installation under E64983.
- ② Standard mounting location — leads exit rear of breaker.
- ③ For use with KT (thermal-magnetic) trip units only.
- ④ Not for use on right pole of 4-pole circuit breaker.
- ⑤ Breakers with K-Frame OPTIM 550 can only accept accessories in left pole.

Undervoltage Release Mechanism

Table 45-226. L-Frame and HMCP (L) Undervoltage Release Mechanism

Voltage Rating (ac Freq. = 50/60 Hz)	Factory Mounted								Field Mounted											
	Connection Type and Location								Field Installation Kits ^①											
	18-Inch (457.2 mm) Pigtail Leads						Terminal Block		Pigtail Leads		Terminal Block									
	Same Side		Rear ^②		Opposite Side		Same Side		Catalog Number	Price U.S. \$	Catalog Number	Price U.S. \$								
Suffix Number	Adder U.S. \$	Suffix Number	Adder U.S. \$	Suffix Number	Adder U.S. \$	Suffix Number	Adder U.S. \$													
Left-Pole Mounting ac Ratings ^②																				
12 Vac	U05			U06				U07				U08			UVH4LP02K			UVH4LT02K		
24 Vac	U09			U10				U11				U12			UVH4LP03K			UVH4LT03K		
48 – 60 Vac	U13			U14				U15				U16			UVH4LP05K			UVH4LT05K		
110 – 127 Vac	U17			U18				U19				U20			UVH4LP08K			UVH4LT08K		
208 – 240 Vac	U21			U22				U23				U24			UVH4LP11K			UVH4LT11K		
380 – 480 Vac	U25			U26				U27				U28			UVH4LP15K			UVH4LT15K		
Right-Pole Mounting ac Ratings ^{③④}																				
12 Vac	U37			U38				U39				U40			UVH4RP02K			UVH4RT02K		
24 Vac	U41			U42				U43				U44			UVH4RP03K			UVH4RT03K		
48 – 60 Vac	U45			U46				U47				U48			UVH4RP05K			UVH4RT05K		
110 – 127 Vac	U49			U50				U51				U52			UVH4RP08K			UVH4RT08K		
208 – 240 Vac	U53			U54				U55				U56			UVH4RP11K			UVH4RT11K		
380 – 480 Vac	U57			U58				U59				U60			UVH4RP15K			UVH4RT15K		
Left-Pole Mounting dc Ratings ^②																				
12 Vdc	T01			T02				T03				T04			UVH4LP20K			UVH4LT20K		
24 Vdc	T05			T06				T07				T08			UVH4LP21K			UVH4LT21K		
48 – 60 Vdc	T09			T10				T11				T12			UVH4LP23K			UVH4LT23K		
110 – 127 Vdc	T13			T14				T15				T16			UVH4LP26K			UVH4LT26K		
220 – 250 Vdc	T17			T18				T19				T20			UVH4LP28K			UVH4LT28K		
Right-Pole Mounting dc Ratings ^{③④}																				
12 Vdc	T21			T22				T23				T24			UVH4RP20K			UVH4RT20K		
24 Vdc	T25			T26				T27				T28			UVH4RP21K			UVH4RT21K		
48 – 60 Vdc	T29			T30				T31				T32			UVH4RP23K			UVH4RT23K		
110 – 127 Vdc	T33			T34				T35				T36			UVH4RP26K			UVH4RT26K		
220 – 250 Vdc	T37			T38				T39				T40			UVH4RP28K			UVH4RT28K		

- ① Listed with Underwriters Laboratories for field installation under E64983.
- ② Standard mounting location — leads exit rear of breaker.
- ③ For use with LT (thermal-magnetic) trip units only.
- ④ Not for use on right pole of 4-pole circuit breaker.

PowerNet and Zone Interlock Kits

**Eaton's Cutler-Hammer
PowerNet and Zone Interlock
Kits (OPTIM 550 only)
K- and L-Frames**

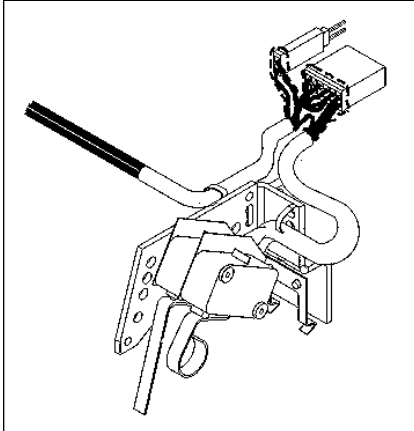

Figure 45-26. PowerNet Communication Kit

Eaton's Cutler-Hammer PowerNet Communications Kit can be ordered to add PowerNet communications to an existing OPTIM 550 breaker in the field. An 18-inch (457.2 mm) wiring pigtail is routed to the rear of the breaker: two wires for PowerNet and two wires for 24 Vdc (45 mA load). It is recommended that the power supply be an "isolated high quality" unit.

Table 45-227. PowerNet and Zone Interlock Kits ①

Circuit Breaker	PowerNet			Zone Interlocking/ Ground ②			PowerNet & Zone Interlocking/ Ground ②		
	Factory Install Suffix	Catalog Number	Price U.S. \$	Factory Install Suffix	Catalog Number	Price U.S. \$	Factory Install Suffix	Catalog Number	Price U.S. \$
K-Frame	PN	ICK550K		ZG	ZGK550K		ZGP	ZGPK550K	
L-Frame	PN	ICK550L		ZG	ZGK550L		ZGP	ZGPK550L	

① Installation of these kits restrict any other attachments from being installed in the RH pole.

② Includes a ground fault alarm signal which can drive the Ground Fault Alarm unit (Catalog Number GFAU).

Termination Hardware

Termination Hardware

End Cap Kit

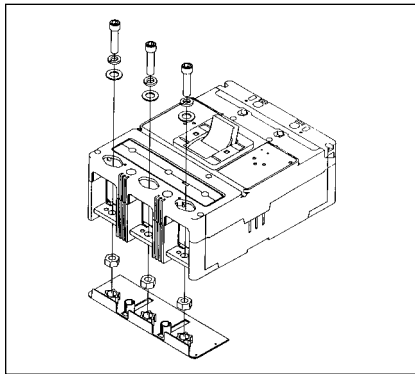

Figure 45-27. End Cap Kit

The End Cap Kit slides onto the line or load conductor of the circuit breaker and acts as a threaded adapter for the conductor to accept a ring terminal or other bolt-on connector. The end cap kit is available with English and metric thread sizes. (Field installation only.) Listed per UL File E7819.

Table 45-228. End Cap Kit

Thread Type	Thread Size	Catalog Number	Price U.S. \$
2-Pole F-Frame (225 A)			
Imperial	10-32	KPEK12	
Metric	M-5	KPEKM12	
3-Pole F-Frame (225 A)			
Imperial	10-32	KPEK1	
Metric	M-5	KPEKM1	
4-Pole F-Frame (225 A)			
Imperial	10-32	KPEK14	
Metric	M-5	KPEKM14	
3-Pole J-Frame			
Imperial	.312-18	KPEK2	
Metric	M-8	KPEKM2	
4-Pole J-Frame			
Imperial	.312-18	KPEK24	
Metric	M-8	KPEKM24	
3-Pole K-Frame			
Imperial	.312-18	KPEK3	
Metric	M-8	KPEKM3	
4-Pole K-Frame			
Imperial	.312-18	KPEK34	
Metric	M-8	KPEKM34	
3-Pole L-Frame			
Imperial	.312-18	KPEK4	
Metric	M-8	KPEKM4	
4-Pole L-Frame			
Imperial	.312-18	KPEK44	
Metric	M-8	KPEKM44	

Keeper Nut

The Keeper Nut slides onto the line or load conductor of the circuit breaker and acts as a threaded adapter for the conductor to accept a ring terminal or other bolt-on connector. The keeper nut is available with English and metric thread sizes. Screws and washers are supplied by customer. (Field installation only.) Listed per UL File E7819.

Table 45-229. F-Frame Keeper Nut

Thread Type	Thread Size	Catalog Number	Price U.S. \$
		Package of 12 (Priced Individually)	
Imperial	10-32	KPR1A	
Metric	M-5	KPR1AM	

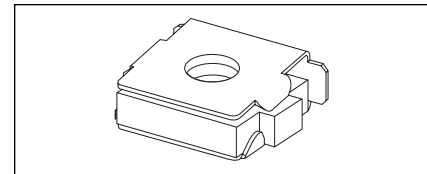

Figure 45-28. F-Frame Keeper Nut

Table 45-230. K-Frame Keeper

Thread Type	Thread Size	Line/Load End	Catalog Number	Price U.S. \$
			Package of 3	
Imperial	.375-16	Line Load	KPR3A	
			KPR3B	
Metric	M-8	Line Load	KPR3AM	
			KPR3BM	

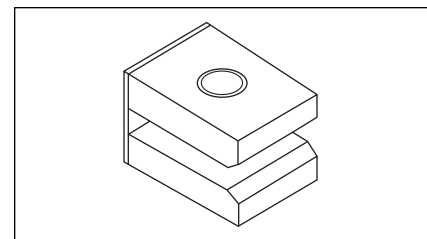

Figure 45-29. K-Frame Keeper Nut

L-Frame

Not required. Terminals are threaded.

Termination Hardware

Plug Nut

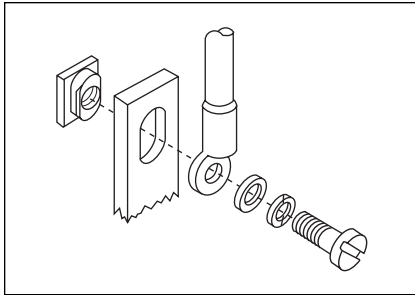

Figure 45-30. J-Frame Plug Nut

The Plug Nut is used in applications where screw-connected ring-type terminals are preferred to connect cables to circuit breaker conductors. The plug nut is press-fit into the opening in the circuit breaker terminal conductor. Screws and washers are supplied by customer.

Table 45-231. J-Frame Plug Nut

Thread Type	Thread Size	Catalog Number Package of 6	Price U.S. \$
Imperial	.250-20	PLN2	
Metric	M-6	PLN2M	

Terminal Adapter

Table 45-232. K-Frame Terminal Adapter ①

Line/Load End	Catalog Number	Price U.S. \$
Line & Load	TAD3	

① K-Frame terminal adapter for use in replacing LB/DA breakers.

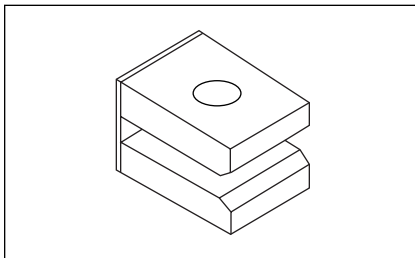

Figure 45-31. K-Frame Terminal Adapter

Control Wire Terminal Kit

Table 45-233. G-Frame Control Wire Terminal

Description	Catalog Number	Catalog Number	Price U.S. \$
Control Wire Terminal (Kit of 12)	5652B38G01	GCWTK	

The Control Wire Terminal Kit provides a means to tap off control power from a main disconnect, using the provided male end of a quick disconnect.

For use with steel or stainless steel terminals only.

Note: Terminal Kits contain one terminal for each pole and one terminal cover.

F-Frame Ordering Information

Package of 12 control wire terminal tangs. Terminals must be ordered separately. Priced individually.

Table 45-234. F-Frame Control Wire Terminal Kit

Maximum Amperes	Catalog Number	Price U.S. \$
150	FCWTK	
225	FCWTK225	

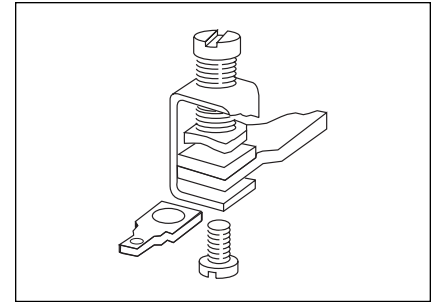

Figure 45-32. F-Frame Kit

Not for use with T250KB terminals.

J- and K-Frame Ordering Information

Package of 12 control wire terminal tangs. Terminals must be ordered separately. Priced individually.

Table 45-235. J- and K-Frame Control Wire Terminal Kit Ordering Information

Catalog Number	Price U.S. \$
KCWTK	

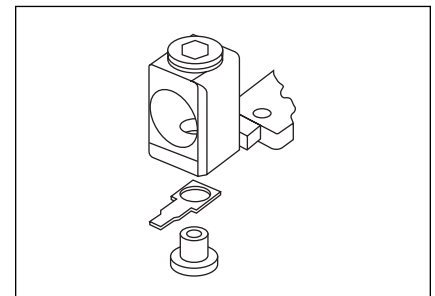

Figure 45-33. J- and K-Frame Kit

Table 45-236. L-Frame Control Wire Terminal Kit

AWG Wire Range/Number Conductors	Metric Wire Range mm ²	Catalog Number	Price U.S. \$
Al/Cu (2) 250 – 350 kcmil	120 – 150	TA602LDCW ②	
Cu (2) 3/0 – 350 kcmil	120 – 150	T602LDCW ②	
Al/Cu (2) 400 – 500 kcmil	185 – 240	2TA603LDKCW ③ 2-Pole Kit	
Al/Cu (2) 400 – 500 kcmil	185 – 240	3TA603LDKCW ③ 3-Pole Kit	
Al/Cu (2) 400 – 500 kcmil	185 – 240	4TA603LDKCW ③ 4-Pole Kit	

② Individually packed.

③ Terminal kits contain one terminal for each pole and one terminal cover.

Multiwire Connectors

Multiwire Connectors

Eaton's Cutler-Hammer field-installed multiwire connectors for the load side (OFF) end terminals, are used to distribute the load from the circuit breaker to multiple devices without the use of separate distribution terminal blocks.

Multiwire lug kits include mounting hardware, insulators and tin-plated aluminum connectors to replace three mechanical load lugs. UL listed for copper only as used on the load side (OFF) end.

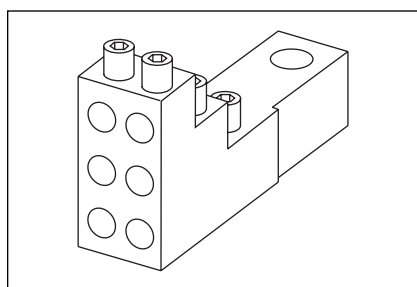

Figure 45-34. Multiwire Connectors

Table 45-237. Multiwire Connectors Ordering Information (Package of 3)

Maximum Amperes	Wires per Terminal	Wire Size Range AWG Cu	Kit Catalog Number	Price U.S. \$
G-Frame				
100	3	14 - 2	3TA100G3K	
100	6	14 - 6	3TA100G6K	
F-Frame				
225	3	14 - 2	3TA150F3K	
225	6	14 - 6	3TA150F6K	
J-Frame				
250	3	14 - 2	3TA250J3K	
250	6	14 - 6	3TA250J6K	
K-Frame				
400	3	14 - 2/0	3TA400K3K	
400	6	14 - 3	3TA400K6K	

Base Mounting Hardware

Base Mounting Hardware

Ordering Information

Hardware for surface mounting of circuit breakers is supplied only on request. Hardware consists of mounting screws and lockwashers. Order hardware for circuit breaker pole configurations as required.

Table 45-238. Mounting Hardware

Screw Length in Inches (mm)	Catalog Number	Price U.S. \$
-----------------------------	----------------	---------------

G-Frame

.138-32 x 2.63 (3.5 x 66.7 mm) Std.	624B375G23	
.138-32 x 3.00 (3.5 x 76.2 mm)	8703C80G05	

Table 45-239. Imperial Thread Mounting Hardware

Number of Poles	Description	Type of Mounting	Catalog Number	Price U.S. \$
-----------------	-------------	------------------	----------------	---------------

F-Frame

1	.164-32 x 3.188-inch Pan-Head Steel Screws, Lockwashers, and Clamps	Individual Group ^①	624B375G01 624B375G02	
2	.164-32 x 1.5-inch Pan-Head Steel Screws and Lockwashers	Individual	4218B80G01	
3, 4	.164-32 x 1.5-inch Pan-Head Steel Screws and Lockwashers	Individual	BMH1	

J-Frame

2, 3, 4	.250-20 x 2.75 inch Pan-Head Steel Screws and Lockwashers	Individual	BMH2	
---------	---	------------	-------------	--

K-Frame

2, 3, 4	.250-20 x 1.5 inch Pan-Head Steel Screws and Lockwashers	Individual	BMH3	
---------	--	------------	-------------	--

L-Frame

2, 3, 4	.250-20 x 1.5 inch Filister-Head Steel Screws and Lockwashers and Flat Washers	Individual	BMH4	
---------	--	------------	-------------	--

^① One set of hardware for two circuit breakers

Table 45-240. Metric Thread Mounting Hardware

Number of Poles	Description	Type of Mounting	Catalog Number	Price U.S. \$
-----------------	-------------	------------------	----------------	---------------

F-Frame

1	M4 – 0.7 x 80 mm Pan-Head Steel Screws, Lockwashers, and Clamps	Individual Group (one set of hardware for two circuit breakers)	4218B80G09 4218B80G10	
2	M4 – 0.7 x 38 mm Pan-Head Steel Screws and Lockwashers	Individual	4218B80G11	
3, 4	M4 – 0.7 x 38 mm Pan-Head Steel Screws and Lockwashers	Individual	BMH1M	

J-Frame

2, 3, 4	M6 – 0.7 x 70 mm Pan-Head Steel Screws and Lockwashers	Individual	BMH2M	
---------	--	------------	--------------	--

K-Frame

2, 3, 4	M6 – 0.7 x 38 mm Pan-Head Steel Screws and Lockwashers	Individual	BMH3M	
---------	--	------------	--------------	--

L-Frame

2, 3	—	Individual	BMH4M	
------	---	------------	--------------	--

Terminal Shields and End Covers

Terminal Shields

Terminal Shields provide protection against accidental contact with live line side terminations. Terminal shields are fabricated from high dielectric insulating material and fasten over the front terminal access openings. Small openings in the shields provide limited access to the terminals for tightening connectors. (Field installation only.)

Table 45-241. G-Frame Terminal Shield

Number Units in Package	Catalog Number	Price U.S. \$
10	GTSK3	



F-Frame

Table 45-242. F-Frame Terminal Shield

Number of Poles	Location	Standard (Package of 10) (Priced Individually)		Special — For use when electrical operator is mounted on circuit breaker	
		Catalog Number	Price U.S. \$	Catalog Number	Price U.S. \$
1	Line	625B229G06		—	
2		625B229G07		—	
3		625B229G08		4210B95G01	
4		625B229G09		4210B95G02	



J-Frame

Table 45-243. J-Frame Terminal Shield

Number of Poles	Location	Catalog Number (Package of 10)	Price U.S. \$
2,3	Line End	1266C07G01	
4		6631C01G01	
2,3	Load End	6641C16G01	
4		6641C16G02	



L-Frame

Table 45-244. L-Frame Terminal Shield

Catalog Number (Package of 1)	Price U.S. \$
314C420G05	



K-Frame

Table 45-245. K-Frame Terminal Shield

Number of Poles	Location	Catalog Number (Package of 10)	Price U.S. \$
2, 3	Line	TS33LN	
4	Line	TS34LN	
3	Load	TS33LD	

Terminal End Covers



F-Frame

Product Description

The Terminal End Covers are designed for use in motor control center applications where, because of confined spaces, line side conductors are normally custom fitted. The molded end covers are made of high dielectric glass-polyester and slide over the line ends of the circuit breaker. Close fitting conductor openings are molded into the end covers. The end cover and circuit breaker case fit together to form terminal compartments that isolate discharged ionizing gases during circuit breaker tripping. Terminal end covers are available with two conductor opening diameters, 0.25-inch (6.4 mm) and 0.41-inch (10.4 mm), and are listed per UL File E7819. (Field installation only.)

Ordering Information

The terminal end cover is available for 3-pole circuit breakers only. Two conductor opening sizes are available. Specify quantity (one per circuit breaker) when ordering.

Table 45-246. F-Frame Terminal End Covers

Conductor Opening Diameter in Inches (mm)	Catalog Number	Price U.S. \$
0.25 (6.35 mm)	TEC1	
0.41 (10.41 mm)	TEC2	

Interphase Barriers

The interphase barriers provide additional electrical clearance between circuit breaker poles for special termination applications. The barriers are high dielectric insulating plates that are installed in the molded slots between the terminals. (Field installation only.) Two per package.



Interphase Barrier

Table 45-247. Interphase Barriers

Frame	Catalog Number	Price U.S. \$
F	IPB1	
J, K	IPB3	
L	IPB4	

Base Mounting Adapters

Base Mounting Plate



Base Mounting Plate

Suitable for mounting (6) single-pole circuit breakers.

**Table 45-248. Base Mounting Plate
G-Frame GD/GHC**

Number Units in Package	Catalog Number	Price U.S. \$
1	207B513G01	

DIN Rail Adapter



DIN Rail Adapter

For use with standard 35 mm DIN Rail such as, 35 x 7.5 or 35 x 15 mm per DIN EN50022.

Adapter mounting screws included are for use with 2- and 3-pole circuit breakers. Adapters for 1-pole circuit breakers (pictured above) clip into the base molding.

**Table 45-249. DIN Rail Adapter
G-Frame GD/GHC**

Poles	Number Units in Package	Catalog Number	Price U.S. \$
1, 2-Pole	10	1225C79G01	
3-Pole	10	1225C79G02 ①	

① For use on 3-pole breakers only.

Key Operated Attachment

**Table 45-250. Key Operated Attachment
G-Frame GD/GHC**

Number Units in Package	Catalog Number	Price U.S. \$
10	GK0A	

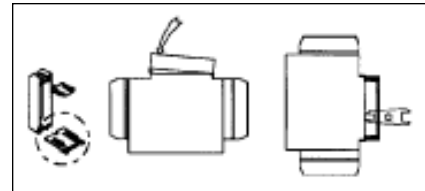

Figure 45-35. Key Operated Attachment

Lock Dog (Non-Padlockable)



Lock Dog (Non-Padlockable)

Table 45-251. Lock Dog (Non-Padlockable) G-Frame GD/GHC/GHB/GMCP

Number Units in Package	Catalog Number	Price U.S. \$
1	1294C01H01	

Non-Padlockable Handle Block

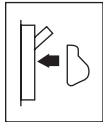

Non-Padlockable Handle Block

Product Description

The Non-Padlockable Handle Block secures the circuit breaker handle in either the ON or OFF position. (Trip-free operation allows the circuit breaker to trip when the handle block holds the circuit breaker handle in the ON position.) The device is positioned over the circuit breaker handle and secured by a setscrew to deter accidental operation of the circuit breaker handle. Listed per UL File E7819. (Field installation only.)

Table 45-252. Non-Padlockable Handle Block

Frame	Catalog Number	Price U.S. \$
F J, K L, M, N	LKD1 LKD3 LKD4	

Padlockable Handle



Padlockable Handle

Table 45-253. Padlockable G-Frame GD/GHC/GHB

Number Units in Package	Catalog Number ①	Price U.S. \$
10	1223C77G03	
10	1223C77G05 ②	
100	1223C77G06 ②	

- ① Accepts .285 Lock Shank
- ② Padlockable in the OFF position only.

Padlockable Handle Lock



Padlockable Handle Lock

The device is positioned in the cover opening to prevent handle movement. Will accommodate one 5/16-inch (8 mm) padlock.

Table 45-254. Padlockable Handle Lock

Frame	Catalog Number	Price U.S. \$
G J, K	GPHBOFF PHB3	

Snap-on Padlockable Handle Lock Hasp



Snap-on Padlockable Handle Lock Hasp

Product Description

The Snap-on Padlockable Handle Lock allows the handle to be locked in the OFF or ON position. (Trip-free operation allows the circuit breaker to trip when the handle lock holds the circuit breaker handle in the ON position.) This device was designed for use on the 1-pole circuit breaker, but may be used on 1-, 2-, 3- and 4-pole styles. The handle lock snaps onto the escutcheon area of the handle with an optional retaining screw for added security. The handle lock will accommodate one padlock with a 1/4-inch (6.4 mm) shackle. Listed per UL File E7819. (Field installation only.)

Table 45-255. Snap-on Padlockable Handle Lock Hasp

Frame	Catalog Number	Price U.S. \$
F	PHL1	

Handle Locking and Blocking Devices

**Padlockable
Handle Lock Hasp**



Padlockable Handle Lock Hasp

Product Description

The Padlockable Handle Lock Hasp allows the handle to be locked in the ON or OFF position. (Trip-free operation allows the circuit breaker to trip when the handle lock holds the circuit breaker handle in the ON position.) The hasp mounts on the circuit breaker cover within the trimline. The cover is predrilled on both sides of the operating handle so that the hasp can be mounted on either side of the handle. The hasp will accommodate up to three padlocks with 1/4-inch (6.4 mm) shackles, one per circuit breaker. Listed per UL File E7819. (Field installation only.)

Table 45-256. Padlockable Handle Lock Hasp

Description	Catalog Number	Price U.S. \$
F-Frame		
1-Pole Breakers	PHL1	
2-, 3-, 4-Pole Breakers	PLK1	
For Left Side Mounting	PLK1LOFF	
For Right Side Mounting	PLK1ROFF	
J, K-Frames		
2-, 3-, 4-Pole Breakers	PLK3	
For Left Side Mounting	PLK3LOFF ①	
For Right Side Mounting	PLK3ROFF ①	
L-Frame (Side Mounted)		
Side Mounted		
Lock ON or OFF	HLK4	
Lock OFF Only (Left-Hand Mount)	HLK4LOFF ①	
L-Frame (Top Mounted)		
Lock ON or OFF	HLK4S	
Lock OFF Only	HLK4SOFF ①	

① For padlockable handle lock hasp to padlock handle in OFF position only order either catalog number.

Cylinder Lock

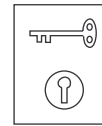

Cylinder Lock

Product Description

The Cylinder Lock internally blocks the trip bar in the tripped position to prevent the circuit breaker from being switched to ON. The cylinder lock is factory installed in the left pole only of the circuit breaker cover. Other internally mounted accessories cannot be installed in the same pole as the cylinder lock. (Factory installation only.)

Table 45-257. Cylinder Lock

Frame	Catalog Number	Price U.S. \$
F, J, K	Order by Description	

**Key Interlock Kit
(Lock Not Included)**



Key Interlock Kit

Product Description

The Key Interlock is used to externally lock the circuit breaker handle in the OFF position. When the key interlock is locked, an extended deadbolt blocks movement of the circuit breaker handle. Uniquely coded keys are removable only with the deadbolt extended. Each coded key controls a group of circuit breakers for a given specific customer installation.

The key interlock assembly is Underwriters Laboratories listed for field installation under UL File E7819 and consists of a mounting kit and a purchaser supplied deadbolt lock. The mounting kit comprises a mounting plate, which is secured to the circuit breaker cover in either the left- or right-pole position, key interlock mounting screws, and a wire seal. Specific mounting kits are required for individual key interlock types.

Ordering Information

Key interlock mounting kits are for field installation only. Select mounting kit catalog numbers to match type of lock used. Key interlocks are supplied by customer.

Table 45-258. Key Interlock Kit

Lock Manufacturer	Lock Type	Bolt Projection in Withdrawn Position in Inches (mm)	Kit Catalog Number	Price U.S. \$
F-Frame				
Superior	B-4003-1	.38 (9.5)	KYK1	
Kirk®	F	.38 (9.5)		
Square D®	SF	None		
Federal Pioneer®	VF	.38 (9.5)		
Castell	K or QK	.38 (9.5)	CTK1	
J, K-Frames				
Superior	B-4003-1	.38 (9.5)	KYK3	
Kirk	F	.38 (9.5)		
Square D	SF	None		
Federal Pioneer	VF	.38 (9.5)		
Castell	K or QK	.38 (9.5)	CTK3	
L-Frame				
Superior	B-4003-1	.38 (9.5)	KYK4	
Kirk	F	.38 (9.5)		
Square D	SF	None		
Federal Pioneer	VF	.38 (9.5)		
Castell	K or QK	.38 (9.5)	CTK4	

Mechanical Interlocking Devices

Sliding Bar Interlock



Sliding Bar Interlock

Product Description

The Sliding Bar Interlock provides mechanical interlocking between two adjacent 3-pole circuit breakers. It is installed on the enclosure cover between the circuit breakers. When the sliding bar interlock handle is moved from one side to the other, a bar extends to alternately block movement of the circuit breaker handles and prevents both circuit breakers from being switched to ON at the same time. Sliding bar interlocks are not UL listed. (Field installation only.)

Walking Beam Interlock

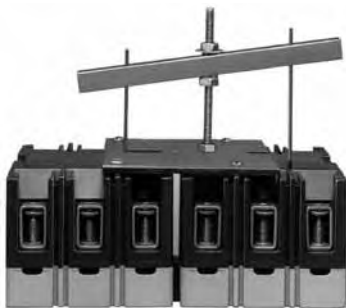

Walking Beam Interlock

Product Description

The Walking Beam Interlock provides mechanical interlocking between two adjacent circuit breakers of the same pole configuration. The walking beam interlock mounts on a bracket behind and between the circuit breakers. A plunger on each end of the beam is inserted through an access hole in the back plate and base of each circuit breaker. The walking beam interlock prevents both circuit breakers from being switched ON at the same time. If a walking beam interlock is installed, the wiring troughs in the back of the circuit breaker case are blocked by the plungers and cannot be used for cross wiring. Factory modified circuit breakers are required for this application. UL File E3816.

Ordering Information

The sliding bar interlock is available for mounting between two adjacent 3-pole circuit breakers with circuit breakers centerline spacing as indicated in table and enclosure front panel thickness of 1/8 or 3/16 inch (3.2 or 4.8 mm). (For field installation only.)

Table 45-259. Walking Beam Interlock

Frame	Catalog Number	Price U.S. \$
F	WBL1	
K	WBL3	
L	WBL4A	

Ordering Information

The walking beam interlock is available for mounting between two adjacent circuit breakers spaced 1/4-inch (6.4 mm) apart and having the same pole configuration. The two circuit breakers must be factory modified to accept the walking beam interlock assembly (suitable for use with either 2-, 3- or 4-pole circuit breakers). With properly modified circuit breakers, the walking beam interlock is suitable for field installation. Order circuit breakers specifying modification for walking beam (20% price adder) and select walking beam interlock from table below. Circuit breakers and walking beam interlock are boxed and shipped separately.

Table 45-260. Sliding Bar Interlock

Frame	Centerline Spacing in Inches (mm)	Catalog Number	Price U.S. \$
F	4.19 (106.4)	SBK1	
J	4.38 (111.3)	SBK2	
K	5.75 (146.0)	SBK3	
L	8.50 (215.9)	SBK4	

Electrical Operator

Electrical Operator

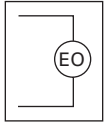

Electrical Operator

Product Description

The Electrical (Solenoid) Operator is a single solenoid mechanism that enables local and remote circuit breaker ON, OFF, and reset switching. The electrical operator is mounted on the circuit breaker cover within the trimline of the circuit breaker. The electrical operator uses a unique bi-stable latch that allows the device to operate using one solenoid. The accessory provides high-speed switching with a maximum operating time of 5 cycles (80 mS), making it suitable for generator synchronizing applications.

Means are provided for remote electrical operation and for local manual operation. A special slide includes provisions for padlocking the circuit breaker handle in the OFF position. The slide will accept three padlock shackles with a maximum diameter of 1/4-inch (6.4 mm) each. An interlock electrically disconnects the solenoid when the electrical operator cover is removed. The Rating Data Tables provide electrical rating data for the electrical (solenoid) operator.

The Electrical (Motor) Operator allows the circuit's breaker to be opened, closed or reset remotely. It also has a lock-off capability and provisions for manual operation.

The Electrical (Motor) Operator contains a reversible motor connected to a ball screw. The ball screw drives the circuit breaker handle. Limit switches and relays are used to control the motor.

Table 45-261. F-Frame Electrical (Solenoid) Operator Rating Data ①②

Voltage ③	Frequency	Inrush Current Amperes	Maximum Operating Time	Fuse ④ Amperes
120 240	50/60 Hz ac	10 5	5 cycles (80 ms)	3 2

- ① UL listed under UL File E64983.
- ② The electrical operator design is endurance tested for 10,000 electrical operations.
- ③ Tolerance: +10%, -15% of nominal voltage.
- ④ Use current-limiting type fuse where required.

Table 45-262. F-Frame Electrical (Solenoid) Operator

Voltage	Frequency	Terminal Block		18-Inch (457.2 mm) Pigtail Lead	
		Catalog Number	Price U.S. \$	Catalog Number	Price U.S. \$
120 240	ac	EOP1T07 EOP1T11		EOP1P07 EOP1P11	

Table 45-263. F-Frame Electrical (Motor) Operator Rating Data ⑤⑥⑦⑧

Voltage ⑨	Frequency	Inrush Current Amperes
120	ac	2
24 48 125	dc	5 3 2

- ⑤ UL listed under UL File E64124.
- ⑥ Frequency: 50/60 Hz.
- ⑦ The electrical operator design has been endurance tested for 4,000 electrical operations.
- ⑧ Maximum operating time: 3 seconds max. Operator is an intermittent duty device. The safe duty cycle (OFF to ON to OFF) should not exceed one per minute.
- ⑨ Tolerance: +10%, -15% of nominal voltage.

Table 45-264. F-Frame Electrical (Motor) Operator

Voltage	Frequency	18-Inch (457.2 mm) Pigtail Lead	
		Catalog Number	Price U.S. \$
120	50/60 Hz ac	MOP1P07	
24 48 125	dc	MOP1P03dc MOP1P05dc MOP1P07dc	

Table 45-265. J-Frame Electrical (Solenoid) Operator Rating Data ⑩⑪⑫⑬

Voltage ⑭	Inrush Current Amperes	Fuse Amperes
120 240	24 12	6 4

- ⑩ UL listed under UL File E64983.
- ⑪ The electrical operator design has been endurance tested for 6,000 electrical operations.
- ⑫ Frequency: 50/60 Hz.
- ⑬ Maximum operating time: 5 cycles (80 mS).
- ⑭ Tolerance: +10%, -15% of nominal voltage.

Table 45-266. J-Frame Electrical (Solenoid) Operator

Operating Voltage	Frequency	Terminal Block	
		Catalog Number	Price U.S. \$
120 240	50/60 Hz ac	EOP2T07 EOP2T11	

Electrical Operator

Table 45-267. K-Frame Electrical (Motor) Operator Rating Data ①②③④

Operating Voltage ⑤	Inrush Current Amperes	Fuse Amperes
120	30	6
240	16	4

- ① UL listed under UL File E64983.
- ② The electrical operator design has been endurance tested for 6,000 electrical operations.
- ③ Frequency: 50/60 Hz.
- ④ Maximum operating time: 5 cycles (80 mS).
- ⑤ Tolerance: +10%, -15% of nominal voltage.

Table 45-268. K-Frame Electrical (Motor) Operator (310 and OPTIM)

Operating Voltage	Frequency	Terminal Block	
		Catalog Number	Price U.S. \$
120	50/60 Hz ac	EOP3MT07	
240		EOP3MT11	

Table 45-269. K-Frame Electrical (Motor) Operator Base Mounting Kit

Frame	Catalog Number	Price U.S. \$
K	BBMK3	

Table 45-270. L-Frame Electrical (Motor) Operator Rating Data ⑥⑦⑧⑨

Operating Voltage ⑩	Inrush Current Amperes
120 ac	8
208	5
240	4
125 dc	9
24	27

- ⑥ UL listed under UL File E64983.
- ⑦ The electrical operator design has been endurance tested for 6,000 electrical operations.
- ⑧ Frequency: 50/60 Hz.
- ⑨ Maximum operating time: 12 cycles.
- ⑩ Tolerance: +10%, -15% of nominal voltage.

Table 45-271. L-Frame Electrical (Motor) Operator (310 and OPTIM)

Operating Voltage	Frequency	Terminal Block	
		Catalog Number	Price U.S. \$
120	50/60 Hz	EOP4MT07	
208		EOP4MT11	
240		EOP4MT11A	
480		EOP4MT15	
125	dc	EOP4MT26	
24		EOP4MT21	

Plug-in Adapters

Plug-in Adapters



Plug-in Adapter

Product Description

Plug-in Adapters simplify installation and front removal of circuit breakers. Individual line and load plug-in adapters are available for rear connection applications on 2-, 3- and 4-pole circuit breakers. Common mounting plates for line- and load-end adapters are available.

One Plug-in Adapter Kit is required for line-end and one for load-end.

**Plug-in Adapters (3-Pole)
Line and Load**



Breaker with Plug-in Block

- FD — PAD3F.
- JD — PAD3JD.
- KD — PAD3K.
- LD — PAD3L.

Table 45-272. F-Frame Ordering Information (Flat Bar Type)

Continuous Current Rating (Amperes)	2-Pole		3-Pole		4-Pole	
	Catalog Number	Price U.S. \$	Catalog Number	Price U.S. \$	Catalog Number	Price U.S. \$
100 – 225	1480D13G01		1480D13G02		1480D13G07 ①	
Mounting Plate	176C511H01		507C047H01		—	

① 100 ampere maximum.

Table 45-273. J-Frame Ordering Information (Flat Bar Type)

Continuous Current Rating (Amperes)	Terminal End	2-Pole		3-Pole		4-Pole	
		Catalog Number	Price U.S. \$	Catalog Number	Price U.S. \$	Catalog Number	Price U.S. \$
250	Line Load 1 Line and 1 Load	1260C86G05 1260C86G07 506C144G27		1260C86G06 1260C86G08 506C144G28		1231C67G01 1231C67G02 —	
Mounting Plate	—	②		PMP23		—	

② Use 3-pole mounting plate for 2-pole circuit breaker.

Table 45-274. K-Frame Ordering Information (Flat Bar Type) — 600 Vac Maximum

Continuous Current Rating (Amperes)	2-Pole		3-Pole		4-Pole	
	Catalog Number	Price U.S. \$	Catalog Number	Price U.S. \$	Catalog Number	Price U.S. \$
400	PAD32		PAD33		—	
Mounting Plate	③		PMP33		—	

③ Use 3-pole mounting plate for 2-pole circuit breaker.

Table 45-275. L-Frame Ordering Information (Threaded Stud Type)

Continuous Current Rating (Amperes)	2-Pole		3-Pole	
	Catalog Number	Price U.S. \$	Catalog Number	Price U.S. \$
600 (Threaded Stud Type)	506C059G03		506C059G04	
600 (Flat Bar Type)	1288C19G01		1288C19G02	
Mounting Plate	504C824H01		504C824H01	

Rear Connecting Studs

Rear Connecting Studs



Product Description

Rear Connecting Studs are available in several sizes to accommodate specific fixed-mounted circuit breaker applications.

Each rear connecting stud assembly consists of one stud and one tube. To maintain proper clearances between poles, select alternate long and short stud assemblies for circuit breakers with more than one pole. One assembly is required for line-end and one for load-end of each pole. Tubes must be ordered separately. Connecting studs are available only with English thread sizes.

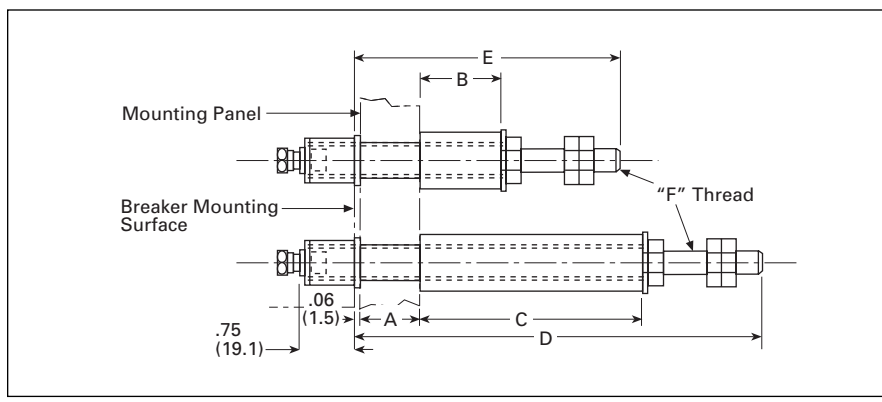

Figure 45-36. F-Frame

Table 45-276. F-Frame Ordering Information — Dimensions in Inches (mm)

Stud Ampere Rating	Stud Catalog Number	Price U.S. \$	Panel Thickness		Tube Length		Tube Catalog Number	Price U.S. \$	Dimensions		
			A		B	C			D	E	F
For 15 to 100 Ampere Circuit Breakers											
100 A Short	451D874G01		1.00 (25.4)		1.06 (26.9)	—	32B9446H20		—	3.63 (92.1)	.31 (7.9) – 18
100 A Short	451D874G01		.69 – .94 (17.5 to 23.8)		1.38 (34.9)	—	32B9446H21		—		
100 A Short	451D874G01		.38 – .63 (9.5 to 15.9)		1.69 (42.9)	—	32B9446H22		—		
100 A Short	451D874G01		.25 – .31 (6.4 to 7.9)		2.00 (50.8)	—	32B9446H23		—		
100 A Long	451D874G02		1.00 (25.4)		—	3.44 (87.3)	32B9446H24		6.13 (155.6)	—	
100 A Long	451D874G02		.69 – .94 (17.5 to 23.8)		—	3.75 (95.2)	32B9446H25		—	—	
100 A Long	451D874G02		.38 – .63 (9.5 to 15.9)		—	4.06 (103.1)	32B9446H26		—	—	
100 A Long	451D874G02		.25 – .31 (6.4 to 7.9)		—	4.38 (111.3)	32B9446H27		—	—	
For 110 to 225 Amperes Circuit Breakers											
225 A Short	374D883G01		1.00 (25.4)		1.06 (26.9)	—	374D883H06		—	4.25 (108.0)	.44 (11.1) – 14
225 A Short	374D883G01		.69 – .94 (17.5 to 23.8)		1.38 (34.9)	—	374D883H07		—		
225 A Short	374D883G01		.38 – .63 (9.5 to 15.9)		1.69 (42.9)	—	374D883H08		—		
225 A Short	374D883G01		.25 – .31 (6.4 to 7.9)		2.00 (50.8)	—	374D883H09		—		
225 A Long	374D883G02		1.00 (25.4)		—	3.44 (87.3)	374D883H10		7.50 (190.5)	—	
225 A Long	374D883G02		.69 – .94 (17.5 to 23.8)		—	3.75 (95.2)	374D883H11		—	—	
225 A Long	374D883G02		.38 – .63 (9.5 to 15.9)		—	4.06 (103.1)	374D883H12		—	—	
225 A Long	374D883G02		.25 – .31 (6.4 to 7.9)		—	4.38 (111.3)	374D883H13		—	—	

45

Discount Symbol CB-2

Rear Connecting Studs

Table 45-277. J-Frame Ordering Information — Dimensions in Inches (mm)

Stud Ampere Rating	Stud Catalog Number	Price U.S. \$	Panel Thickness		Tube Length		Tube Catalog Number	Price U.S. \$
			A		B	C		
250 A Short	5010D23G01		.75 - 1.00 (19.1 - 25.4)		.84 (21.4)	—	456D983H05	
250 A Short	5010D23G01		.50 - .75 (12.7 - 19.1)		1.09 (27.7)	—	456D983H06	
250 A Short	5010D23G01		.25 - .50 (6.4 - 12.7)		1.03 (26.2)	—	456D983H07	
250 A Long	5010D23G02		.75 - 1.00 (19.1 - 25.4)		—	3.88 (98.6)	5010D23H05	
250 A Long	5010D23G02		.50 - .75 (12.7 - 19.1)		—	4.13 (104.9)	5010D23H06	
250 A Long	5010D23G02		.25 - .50 (6.4 - 12.7)		—	4.38 (111.3)	5010D23H07	

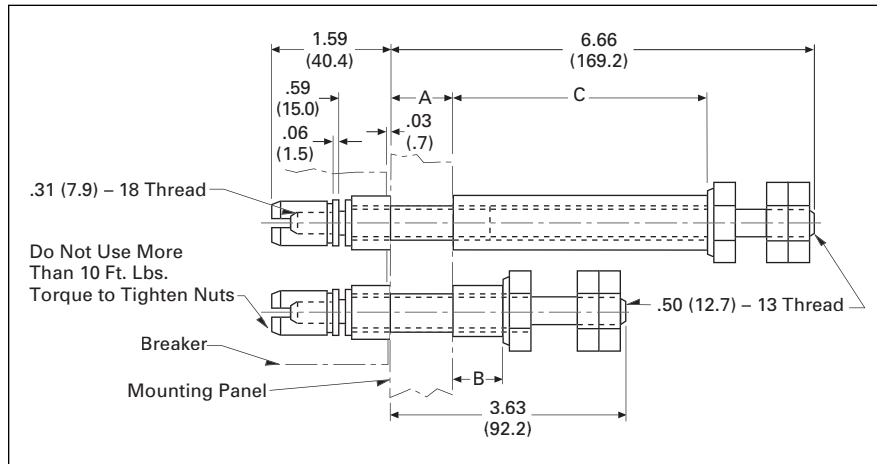

Figure 45-37. J-Frame

Table 45-278. K-Frame Ordering Information — Dimensions in Inches (mm)

Stud Ampere Rating	Stud Catalog Number	Price U.S. \$	Panel Thickness		Tube Length		Standard Tube Catalog Number	Price U.S. \$	Dimensions		
			A		B	C			D	E	F
400 A Short	6642C14G02		.75 - 1 (19.1 - 25.4)		.84 (21.3)	—	313C909H17		—	3.66 (93.0)	.75 - 16 (19.1 - 406.4)
400 A Short	6642C14G04		.50 - .75 (12.7 - 18.4)		1.09 (27.69)	—	313C909H18		—	—	—
400 A Short	6642C14G06		.25 - .5 (6.35 - 12.7)		1.03 (26.16)	—	313C909H19		—	—	—
400 A Long	6642C14G03		.75 - 1 (19.1 - 25.4)		—	3.78 (96.0)	313C909H20		—	—	—
400 A Long	6642C14G05		.50 - .75 (12.7 - 18.4)		—	4.03 (102.4)	313C909H21		6.58 (167.1)	—	—
400 A Long	6642C14G07		.25 - .5 (6.35 - 12.7)		—	4.28 (108.7)	313C909H22		—	—	—

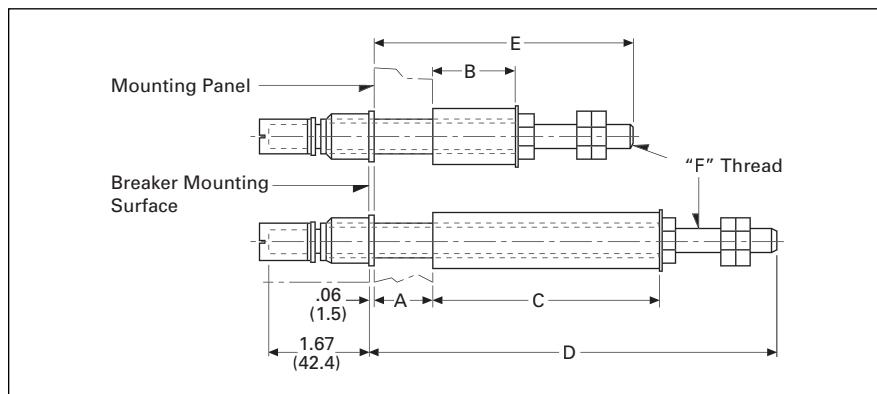

Figure 45-38. K-Frame

Rear Connecting Studs

**Table 45-279. L-Frame Ordering Information
— Dimensions in Inches (mm)**

Stud Length (A)	Stud Catalog Number	Price U.S. \$
5.47 (138.9)	314C960G07	
7.97 (202.4)	314C960G08	
10.47 (265.9)	314C960G09	

Table 45-280. Plug-in Kits

Kit Types	Catalog Number	Price U.S. \$
J Plug-in Kit	PIL2K	
K Plug-in Kit	PIL3K	

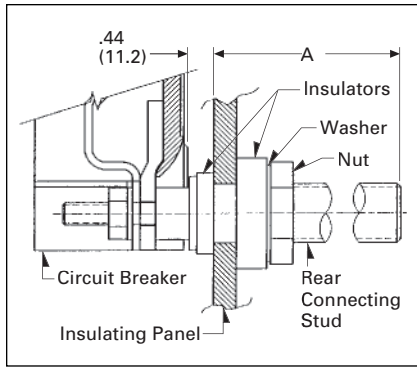

Figure 45-39. L-Frame

Panelboard Connecting Straps

Panelboard Connecting Straps



Panelboard Connecting Straps

Product Description

Panelboard Connecting Straps are used to connect the circuit breaker terminals to the panelboard bus. The panelboard connecting straps are available with various ratings for outside and center poles. (Field installation only.)

Panelboard connecting straps are available to meet the needs of most standard panelboard applications. Style numbers for mounting brackets for CDP panelboard installations are also included.

Refer to panelboard manufacturer for compatibility.

Table 45-281. F-Frame Panelboard Connecting Straps

Bus Spacing in Inches (mm)	Continuous Current Rating (Amperes)	Pole Connector Type			
		Center		Outside	
		Catalog Number	Price U.S. \$	Catalog Number	Price U.S. \$
2.75 (69.9)	50	673B142G02		673B142G09	
2.75 (69.9)	100	673B142G02		673B142G10	
2.75 (69.9)	150	673B142G04		673B142G03	
3.50 (88.9)	50	1253C72G01		1253C72G03	
3.50 (88.9)	100	1253C73G03		1253C73G06	
3.50 (88.9)	150	1253C73G01		1253C73G05	

Table 45-282. F-Frame Mounting Bracket

Number of Poles	Catalog Number	Price U.S. \$
2	624B600H02	
3	624B600H01	

Table 45-283. J-Frame Panelboard Connecting Straps

Bus Spacing in Inches (mm)	Continuous Current Rating (Amperes)	Pole Connector Type			
		Center		Outside	
		Catalog Number	Price U.S. \$	Catalog Number	Price U.S. \$
3.50 (88.9)	250	2600D26G01		2600D26G02	

Table 45-284. J-Frame Mounting Bracket

Number of Poles	Catalog Number	Price U.S. \$
2, 3	1576707	

Table 45-285. K-Frame Panelboard Connecting Straps

Bus Spacing in Inches (mm)	Continuous Current Rating (Amperes)	Pole Connector Type			
		Center		Outside	
		Catalog Number	Price U.S. \$	Catalog Number	Price U.S. \$
3.50 (88.9)	400	4212B78G02		4212B77G01	

Table 45-286. K-Frame Mounting Bracket

Number of Poles	Catalog Number	Price U.S. \$
2, 3	208B264H01	

Table 45-287. L-Frame Panelboard Connecting Straps

Continuous Current Rating (Amperes)	Pole Connector Type			
	Center		Outside	
	Catalog Number	Price U.S. \$	Catalog Number	Price U.S. \$
600	624B609G01		506C052G01	

Table 45-288. L-Frame Mounting Bracket

Number of Poles	Catalog Number	Price U.S. \$
2, 3	208B297H01	

Handle Mechanisms

Handle Mechanisms
Overview

Handle Mechanisms are used to operate molded case circuit breakers, molded case switches and motor circuit protectors. They are available in three basic configurations — Flange Mounted, Through-the-Door and Direct (Close-Coupled) — providing safe, dependable operation and ease of installation.

- Flange Mounted:
 - Flex Shaft
 - C371
- Through-the-Door:
 - Series C Rotary
 - Universal Rotary
- Direct (Close-Coupled):
 - Universal Direct
 - Euro IEC
 - G Direct

Handle mechanisms are typically used on enclosed circuit breakers, control panels and motor control centers in many different applications. Eaton has a handle mechanism for virtually any need.

Flange Mounted Handle Mechanisms

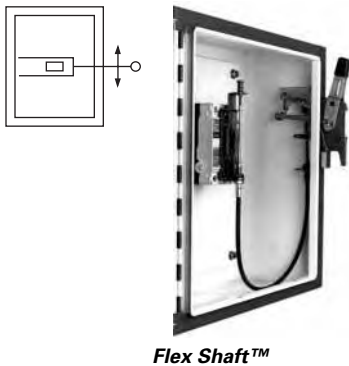

Flex Shaft™

Product Description

Flange Mounted Handle Mechanisms mount on the flange of an enclosure door. The Flex Shaft™ is an extra heavy-duty mechanism that includes a flexible shaft in various lengths, 3 feet (.9 m) through 10 feet (3 m) for use with various size enclosures.

The Flex Shaft Handle will accept up to three padlock shackles, each with a maximum diameter of 3/8-inch (9.5 mm). Can be used with NEMA 1, 3R and 12 fabricated enclosures. An optional handle is available for Flex Shaft that is suitable for use with NEMA 4 and 4X environments. Flex Shaft comes preset from the factory, requiring only minor field adjustments on installation, which takes about 10 minutes — a significant time savings compared to installation of other types of flange handle mechanisms. The

Flex Shaft mechanism also takes up less interior enclosure space than competitive designs and the handle fits standard flange cutouts. Flex Shaft Handle can be remotely mounted from breaker, where an operator can use it by “funneling” the cable through conduit.

Flex Shaft is UL listed under File E64983 and meets CSA requirements.

The Type C371 Circuit Breaker Operating Mechanisms are designed for installation in control enclosures where main or branch circuit protective devices are required. All circuit breaker mechanisms are suitable for right-hand mounting.

Auxiliary contacts are not available for mounting on operating mechanisms. Where required, have them installed in circuit breaker.

Type C371 is UL listed under File E62635.

Table 45-289. Flex Shaft Ordering Information

Breaker Frame	Flexible Shaft Length in Feet (m)							
	3 (.9)		4 (1.2)		5 (1.5)		6 (1.8)	
	Catalog Number	Price U.S. \$	Catalog Number	Price U.S. \$	Catalog Number	Price U.S. \$	Catalog Number	Price U.S. \$
G	F0S03C		F0S04C		F0S05C		F0S06C	
F	F1S03C		F1S04C		F1S05C		F1S06C	
F (Dual)	F1S03CD		F1S04CD		F1S05CD		F1S06CD	
J	F2S03C		F2S04C		F2S05C		F2S06C	
K	F3S03C		F3S04C		F3S05C		F3S06C	
L	N/A		F4S04C		F4S05C		F4S06C	

Table 45-289. Flex Shaft Ordering Information (Continued)

Breaker Frame	Flexible Shaft Length in Feet (m)							
	7 (2.1)		8 (2.4)		9 (2.7)		10 (3.0)	
	Catalog Number	Price U.S. \$	Catalog Number	Price U.S. \$	Catalog Number	Price U.S. \$	Catalog Number	Price U.S. \$
G	N/A		N/A		N/A		N/A	
F	F1S07C		F1S08C		F1S09C		F1S10C	
F (Dual)	F1S07CD		F1S08CD		F1S09CD		F1S10CD	
J	F2S07C		F2S08C		F2S09C		F2S10C	
K	F3S07C		F3S08C		F3S09C		F3S10C	
L	N/A		N/A		N/A		F4S10C	
LG	LHMFS07		LHMFS08		LHMFS08		LHMFS10	

Note: Type 4/4X handle mechanisms are available. Add Suffix X to complete catalog number. Add Suffix I to complete catalog number for IEC handle. Original narrow handle design (No C Suffix) is available. Remove C from catalog number.

Note: When selecting the length of shaft, ensure minimum bending radius of 4 inches (101.6 mm) is maintained to operate properly. The standard method of shipment includes the mechanism preset at the factory; however, minor field adjustments may be required.

Note: Dual breakers operator available on F-Frame only. Only the F, J & K can mount LH & RH all other RH only.

Handle Mechanisms

Table 45-290. Type C371 Ordering Information — Dimensions in Inches (mm)

Circuit Breaker or Motor Circuit Protector	Frame Size	Variable Depth Mounting Range Min/Max ①②	Operating Mechanism Only ③		Operating Mechanism w/ 4-inch Handle			
			Catalog Number	Price U.S. \$	For NEMA 1-12 Enclosure		For NEMA 4/4X Enclosure	
					Catalog Number	Price U.S. \$	Catalog Number	Price U.S. \$
HMCP & Series C EHD, FDB, FD, FDC, HFD, ED	150	6.5 – 16 (165.1 – 406.4)	C371E		C371E1		C371E2	
HMCP & Series C HJD, JD, JDB, JDC	250	6.5 – 16.63 (165.1 – 422.4)	C371F		C371F5		C371F6	
HMCP & Series C DK, HKD, KD, KDB	400	6.5 – 16.63 (165.1 – 422.4)	C371F		C371F5		C371F6	
Series C HLD, LD, LDC	600	8.5 – 22 (215.9 – 558.8)	C371G		C371G5		C371G6	
Series C MD, MDS (No MDL)	800	8.75 – 22 (222.3 – 558.8)	C371K		C371K5		C371K6	
Series C HND, ND, NDC	1200	9.75 – 22 (247.7 – 558.8)	C371K		C371K5		C371K6	

- ① For increased maximum allowable depth, see connecting rods right.
- ② Dimensions shown are from panel flange surface.
- ③ Does not include handle.

Table 45-291. Handle Only — Dimensions in Inches (mm)

Circuit Breaker Frame Size (Amperes)	NEMA Enclosure Type	Operating Handle Length	Catalog Number	Price U.S. \$
150	1-3R-3-12 4/4X	4 (101.6)	C371H1 C371H2	
	1-3R-3-12 4/4X	6 (152.4)	C371H3 C371H4	
250 – 1200	1-3R-3-12 4/4X	4 (101.6)	C371H5 C371H6	
	1-3R-3-12 4/4X	6 (152.4)	C371H7 C371H8	

Table 45-292. Channel Support Kit (Rod Not Supplied)

For use to prevent bending of the operating handle mounting surface. This is especially useful when the operating handle is mounted on a channel in a multi-door enclosure. Included in 600 – 1200 A.

Catalog Number	Price U.S. \$
C371CS6	

Table 45-293. Connecting Rods ④

Application	Catalog Number	Price U.S. \$
Disconnect Switches (30, 60, 100, 200 A Sizes)	C371CS1	
Circuit Breakers (150, 250, 400 A Sizes)	C371CS1	
Circuit Breakers (600, 800, 1200 A Sizes)	C371CS2	

- ④ Increase maximum allowable depth by 5 inches (127 mm).

Flex Shaft Accessories (F- through L-Frame)

Table 45-294. NEMA 12 Safety Door Hardware for Flex Shaft and C371 ⑤

Handle Length in Inches (mm)	Catalog Number ⑥	Price U.S. \$
4 (101.6)	C361KJ4	
6 (152.4)	C361KJ6	
Roller Latch ⑦	C361KR	

- ⑤ Customer: Consult with box manufacturer for correct door hardware and any adapters required for assembly.
- ⑥ The 1/4-inch x 1/2-inch (6.35 x 12.7 mm) standard mill rectangular locking bar is not supplied with these kits.
- ⑦ Third roller latch for use with 4- or 6-inch (101.6 or 152.4 mm) handle when 3 point latching is required.

Handle Mechanisms

**Through-the-Door
Handle Mechanisms**

Eaton's Cutler-Hammer through-the-door handle mechanisms mount on the front of an enclosure or cabinet door and externally operate the circuit breaker via a variable depth shaft or a linear operator (Type MC). Each rotary type handle mechanism includes a handle, base operating mechanism and shaft that can be cut to various lengths.

Series C Rotary and Universal Rotary handle mechanisms are for use with Molded Case Circuit Breakers (G, F, J, K, L, MDL), Molded Case Switches and Motor Circuit Protectors.

Series C Rotary is suitable for use with NEMA 1, 3R, 12 and 4/4X enclosure types. Type 4/4X application requires special handle, see "Ordering Information."

The Universal Rotary is suitable for use with NEMA 1 and 12 enclosure types. All rotary handle mechanisms include a handle "Lock Off," to prevent turning the breaker ON while in the OFF position. All rotary handles indicate ON/OFF/Tripped/Reset positions, however, Universal Rotary has the added feature of international markings for ON (I) and OFF (O). Series C Rotary handle is metal. Universal Rotary is made of molded material. Series C Rotary handle is black and Universal Rotary is available in black or yellow/red.

Series C Rotary handle was ergonomically designed with extra clearance for a "gloved hand" to operate. Handle has a 45° rotation. Universal Rotary has a 90° rotation ("pipe valve" operation) where ON is vertical and OFF is horizontal. Shafts include a support brace to ensure proper alignment.

In addition, the 16-inch (406.4 mm) and 24-inch (609.6 mm) extra long shafts include an adjustable support bracket.

Series C Rotary and Universal Rotary, are UL listed and meet CSA requirements. Universal Rotary also meets IEC947-1/2 for international compliance. Rotary UL File Number is E64983.



Series C Rotary

Table 45-295. Series C Rotary Ordering Information

Shaft Length Inches (mm)	Complete Catalog Number ①	Price U.S. \$	Separate Catalog Number						Catalog Number				
			Standard Handle ②	Price U.S. \$	Breaker Mechanism ③	Price U.S. \$	Shaft ④	Price U.S. \$	IEC IP65 ⑤⑥	Price U.S. \$	IEC IP66 ⑤⑥	Price U.S. \$	
F-Frame													
6 (152.4)	HM1R06		6648C22G01		6648C23G11		4217B37G04			WHM1R06		WHM1R06X	
12 (304.8)	HM1R12		6648C22G01		6648C23G11		4217B37G01			WHM1R12		WHM1R12X	
16 (406.4)	HM1R16		6648C22G01		6648C23G11		4217B37G02			WHM1R16		WHM1R16X	
24 (609.6)	HM1R24		6648C22G01		6648C23G11		4217B37G03			WHM1R24		WHM1R24X	
J-Frame													
6 (152.4)	HM2R06		6648C22G01		6648C23G21		4217B37G04			WHM2R06		WHM2R06X	
12 (304.8)	HM2R12		6648C22G01		6648C23G21		4217B37G01			WHM2R12		WHM2R12X	
16 (406.4)	HM2R16		6648C22G01		6648C23G21		4217B37G02			WHM2R16		WHM2R16X	
24 (609.6)	HM2R24		6648C22G01		6648C23G21		4217B37G03			WHM2R24		WHM2R24X	
K-Frame													
6 (152.4)	HM3R06		6648C22G01		6648C23G25		4217B37G04			WHM3R06		WHM3R06X	
12 (304.8)	HM3R12		6648C22G01		6648C23G25		4217B37G01			WHM3R12		WHM3R12X	
16 (406.4)	HM3R16		6648C22G01		6648C23G25		4217B37G02			WHM3R16		WHM3R16X	
24 (609.6)	HM3R24		6648C22G01		6648C23G25		4217B37G03			WHM3R24		WHM3R24X	
L-Frame													
6 (152.4)	HM4R06		6648C22G11		6648C23G19		4217B37G04			WHM4R06		WHM4R06X	
12 (304.8)	HM4R12		6648C22G11		6648C23G19		4217B37G01			WHM4R12		WHM4R12X	
16 (406.4)	HM4R16		6648C22G11		6648C23G19		4217B37G02			WHM4R16		WHM4R16X	
24 (609.6)	HM4R24		6648C22G11		6648C23G19		4217B37G03			WHM4R24		WHM4R24X	

- ① Complete catalog number includes the standard handle, mechanism, shaft and support brace/bracket.
- ② Handle is designed suitable for NEMA Types 1, 3R and 12 enclosures. Use style number **6648C22G03** for Type 4/4X handle or add **X** Suffix to complete catalog number. Handle is cast aluminum.
- ③ Breaker mechanism includes a shaft support bracket and its parts. Shaft is .50-inch (12.7 mm).
- ④ Longer shafts, 16-inch (406.4 mm) and 24-inch (609.6 mm), include an adjustable support extension.
- ⑤ IEC Handle Mechanism supplied with Metric thread mounting hardware.
- ⑥ Complete catalog number includes a handle, mechanism and shaft.

45

Discount Symbol..... **CB-2**

Handle Mechanisms

Type 4/4X handles are similar to standard handles except they include an internal neoprene gasket. Type 4/4X handle style number is 6648C22G03. Due to gasketing effect between the handle and the housing, the handle may not indicate a tripped position.

Series C Rotary Accessories

As an option, an auxiliary switch is offered so that the control panel builder may electrically indicate the status of the breaker. This accessory would be mounted on the mechanism and comes with 24-inch (609.6 mm) pigtail leads.

Table 45-296. Series C Auxiliary Switch

Catalog Number	Price U.S. \$
5108A61G01	

Note: Refer to *YES Catalog* for replacement type Vari-depth and AMT handle mechanisms.

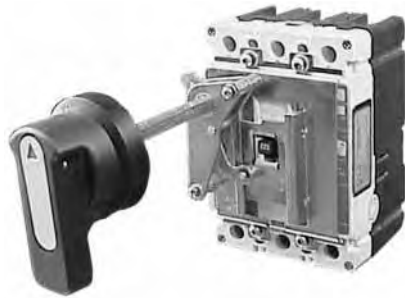

Universal Rotary F-Frame

Table 45-297. Series C Universal Rotary Ordering Information

Shaft Length in Inches (mm)	Handle Color	Complete Catalog Number	Price U.S. \$
F-Frame			
6 (152.4)	Black	FHMVD06B	
12 (304.8)	Black	FHMVD12B	
6 (152.4)	Red	FHMVD06R	
12 (304.8)	Red	FHMVD12R	
G-Frame			
6 (152.4)	Black	GHMVD06B	
12 (304.8)	Black	GHMVD12B	
6 (152.4)	Red	GHMVD06R	
12 (304.8)	Red	GHMVD12R	
J-Frame			
6 (152.4)	Black	JHMVD06B	
12 (304.8)	Black	JHMVD12B	
6 (152.4)	Red	JHMVD06R	
12 (304.8)	Red	JHMVD12R	
K-Frame			
6 (152.4)	Black	KHMVD06B	
12 (304.8)	Black	KHMVD12B	
6 (152.4)	Red	KHMVD06R	
12 (304.8)	Red	KHMVD12R	
L-Frame			
6 (152.4)	Black	LHMVD06B	
12 (304.8)	Black	LHMVD12B	
6 (152.4)	Red	LHMVD06R	
12 (304.8)	Red	LHMVD12R	

Handle Mechanisms

**Direct (Close-Coupled)
Handle Mechanisms**

Product Description

Direct (Close-Coupled) Handle Mechanisms mount directly to the circuit breaker. They are used in shallow enclosures where the standard variable depth Through-the-Door type mechanism is not practical or cannot be used. They are typically for applications where high volume, standardized enclosures are being fabricated.

The Universal Direct handle mechanism is designed exclusively for the new Cutler-Hammer E125 and J250 circuit breakers by Eaton Corporation. It is available as standard with a door interlock to prevent opening the enclosure while the circuit breaker is in the ON position. It is also available without a door interlock.

The Euro IEC Direct handle mechanism can be used on F- through R-Frames.

The G Direct is available with a black or the yellow handle, and with or without a shroud. It is suitable for use with NEMA 1 enclosures. It is for use only with the G-Frame (GD, GC, GHC, GMCP).

An escutcheon ring and interlock clip are provided as standard. The standard design includes a lock-off feature.

The Universal Direct handle mechanism is UL 489 listed, IEC947-1/2 and meets CSA requirements. The Euro IEC Direct handle mechanism is IEC-240-1. G Direct is UL listed and meets CSA requirements.

Table 45-298. Euro IEC Direct Ordering Information

Frame	Black Handle		Red Handle	
	Catalog Number	Price U.S. \$	Catalog Number	Price U.S. \$
F	HMCC1B		HMCC1R	
J	HMCC2B		HMCC2R	
K	HMCC3B		HMCC3R	
L	HMCC4B		HMCC4R	



G Direct

Table 45-299. G Direct Ordering Information ①

Frame	Black Handle				Yellow Handle			
	with Shroud		without Shroud		with Shroud		without Shroud	
	Catalog Number	Price U.S. \$	Catalog Number	Price U.S. \$	Catalog Number	Price U.S. \$	Catalog Number	Price U.S. \$
GD/ GHC	HRGCC1S		HRGCC10		HRGCC3S		HRGCC30	
GMCP	HRGMC1S		HRGMC10		HRGMC3S		HRGMC30	

① Suitable for use on 2- or 3-Pole G-Frame.

Handle Extension



Handle Extension

Handle Extension is not included with J, K, L, M and N-Frame breakers. It must be purchased separately.

Table 45-300. Handle Extension

Frame	Style Number	Price U.S. \$
J, K	HEX3	
L, M	HEX4	

Type LFD Current Limiter



The LFD Current Limiter is an accessory that bolts to the load end of a standard FDB or FD thermal-magnetic circuit breaker, providing 200,000 A interrupting capacity at up to 600 Vac. LFD current limiters for thermal-magnetic circuit breakers are listed with Underwriters Laboratories under File E47239.

Table 45-301. Type LFD Current Limiter

Circuit Breaker Rating Amperes	Catalog Number	Price U.S. \$
15 – 70	LFD3070R	
80 – 160	LFD3150R	

Ground Fault Alarm Unit



The Ground Fault Alarm Unit is a remotely mounted device with a combination indicating light/test button that will light when the breaker trips or alarms on ground fault. The Ground Fault Alarm Unit requires a separate 120 Vac power source to power the light and the internal relay which has 1NO and 1NC contacts for remote indication. The Ground Fault Alarm Unit can be panel mounted for ordering with an optional face mounting bracket. For use on Digitrip 310 only, K- through N-Frame.

Table 45-302. GF Alarm Unit

Description	Catalog Number	Price U.S. \$
Ground Fault Alarm Unit	GFAU	
Face Mounting Bracket	1264C67G01	

IQ Energy Sentinel



The IQ Energy Sentinel is a highly accurate, microprocessor-based, breaker-mounted device designed to monitor power and energy readings. It represents an alternative to watt meters, watt-hour meters, and watt demand meters. Key advantages include savings in space, lower installation costs, and remote monitoring capability.

The IQ Energy Sentinel mounts on the load side of a Series C F-Frame (150 ampere) circuit breaker. It can be applied on 3-phase, 4-wire systems, or single-phase, 3-wire systems with voltage connected through phases A and C.

For more information, see Descriptive Bulletin 8178.

Potential Transformer Module



The Potential Transformer Module is required for the Digitrip OPTIM 1050 to provide a voltage input to allow the trip unit to monitor power and energy as well as power factor. The Potential Transformer Module is a 6 VA transformer with a primary voltage input of up to 600 volt line to line. Three 0.1 ampere fuses are provided on the primary of the transformer and can be used for isolation purposes during dielectric testing. The device is normally panel mounted and can feed up to 16 OPTIM trip units.

Table 45-303. Potential Transformer Module

Description	Catalog Number	Price U.S. \$
Potential Transformer Module	DOPTMLN	

Solid-State (Electronic) Portable Test Kit

The Solid-State (Electronic) Portable Test Kit provides verification of performance of all ratings of Digitrip 310 electronic trip units installed in circuit breakers while in service under varying load and/or phase imbalance. The test kit operates on 120-volt, 50/60 Hz power; it includes complete instructions and test times for testing long time, short time/instantaneous operation and optional ground fault operation of the circuit breaker.

Table 45-304. Portable Test Kit

Description	Catalog Number	Price U.S. \$
Solid-State (Electronic) Portable Test Kit	STK2	

OPTIM System Components

Breaker Interface Module (BIM)



The Breaker Interface Module (BIM) is a panel mounted user interface device that is mounted on the front of an electrical assembly or at a remote location. The BIM is used to access, configure, test and display information for OPTIM trip units and other devices. The BIM consists of four display windows, eight function buttons, 18 LEDs, and a graphical time/current curve to provide breaker status, operational information, protection status and energy monitoring. A 24 Vdc power supply is required to provide power to the BIM. This is supplied by the switchboard builder to Eaton's specifications. The BIM is a member of Eaton's Cutler-Hammer PowerNet family of communicating devices that connects OPTIM trip units, Digitrip RMS 810/910 trip units and energy sentinels as a subnetwork system. The BIM can also be connected to a main network via a PONI module to PowerNet software.

Table 45-305. Breaker Interface Module (BIM)

Catalog Number	Price U.S. \$
BIMII	

Digitrip OPTIMizer



The Digitrip OPTIMizer is a hand-held programmer that is used to access, configure, test and display information from OPTIM trip units. The OPTIMizer plugs into the front of an OPTIM trip unit via an eight-pin telephone jack and is powered by a nine-volt battery or the auxiliary power module. One highlighted feature is the "Copy" and "Download" commands. Setting up multiple OPTIM trips can be finished in minutes and with no errors. An Auxiliary Power Module connection provides a trip test when control power is not present at the breaker. The OPTIMizer is supplied as a standard package to include the programmer, the eight-pin connection cord, battery and carrying case. The Auxiliary Power Module is optional.

Table 45-306. Digitrip OPTIMizer

Catalog Number	Price U.S. \$
OPTIMizer — Standard Package	

Note: 24 Vdc Power Supply

A 24 Vdc power supply is required for all Digitrip OPTIM trip units that are required to communicate either on the main Eaton's Cutler-Hammer PowerNet network or as a subnetwork to a BIM. The breaker's load is 45 mA of current. Typically one power supply is required per switchboard and can provide control power to a BIM and the OPTIM trip units. The 24 Vdc power supply should be an "isolated high quality" power supply with a "CE" label, and is normally provided by the switchboard manufacturer to Eaton's recommendations.

Auxiliary Power Module



The Auxiliary Power Module is a power supply requiring 120 Vac input at 50 or 60 Hz that provides a 32 Vdc output. The Auxiliary Power Module provides control power for testing an OPTIM trip unit when other means of control power is not available or for continuous OPTIMizer operation versus temporary with a battery. The Auxiliary Power Module connects into the top of the Digitrip OPTIMizer via a keyed receptacle. The main application for the Auxiliary Power Module would be for the testing of a stand-alone non-communicating OPTIM breaker that ordinarily would not have control power.

Note: The OPTIMizer can work off of 32 Vdc control power, although 24 Vdc is the standard on OPTIM breakers.

Table 45-307. Auxiliary Power Module

Catalog Number	Price U.S. \$
PRTAAPM	

CSA is a registered trademark of the Canadian Standards Association. National Electrical Code and NEC are registered trademarks of the National Fire Protection Association, Quincy, Mass. NEMA is the registered trademark and service mark of the National Electrical Manufacturers Association. UL is a federally registered trademark of Underwriters Laboratories Inc. Kirk is a registered trademark of the Kirk Key Interlock Company LLC. Square D is a federally registered trademark of SNA Holdings Inc. Federal Pioneer is a federally registered name of Electro-Mechanical Corporation. Cutler-Hammer is a federally registered trademark of Eaton Corporation.

45